



Mercedes C Coupé Phase I (type C205) + C Cabrio A205

10/'15 - 06/'18

STANDARD ✓ ... AMG-LINE ✓

10/'16 - 06/'18

STANDARD ✓ AMG-LINE ✓



Mercedes C Coupé Phase II (type C205) + C Cabrio A205

07/'18 -

STANDARD ✓ AMG-LINE ✗

07/'18 -

STANDARD ✓ AMG-LINE ✗

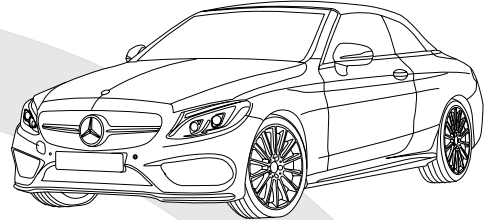
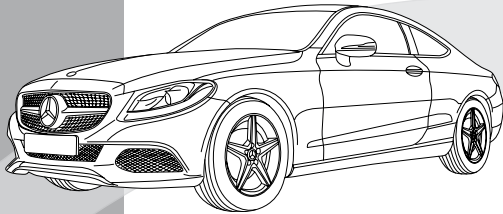

Mercedes C W205 + C Break S205

12/'13 -

09/'14 -

STANDARD ✓

AMG-LINE ✗

PLUG-IN HYBRIDE ✓

HYBRIDE ✓

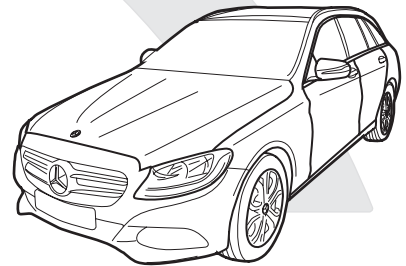
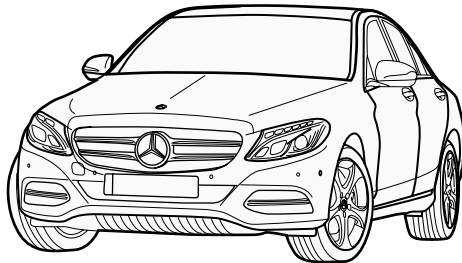

Mercedes E W213 + Facelift + E Break S213 + Facelift

04/'16 - 05/'20

06/'20-

10/'16 - 06/'20

07/'20-

STANDARD ✓

AMG-LINE ✓

ALL-TERRAIN ✓

PLUG-IN HYBRIDE ✓

HANDSFREE TAILGATE ✗

STANDARD ✓

AD BLUE ✓

AMG-LINE ✓

PLUG-IN HYBRIDE ✓

STANDARD ✓

AMG-LINE ✓

ALL-TERRAIN ✓

PLUG-IN HYBRIDE ✓

STANDARD ✓

AD BLUE ✓

AMG-LINE ✓

PLUG-IN HYBRIDE ✓

HANDSFREE TAILGATE ✗

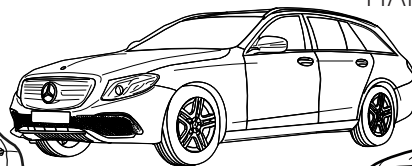
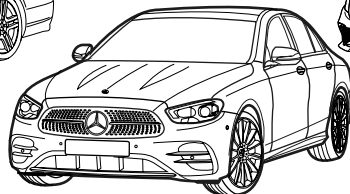
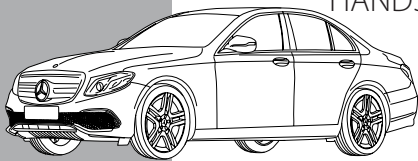

Mercedes E Coupé C238 + E Cabrio (A238)

12/'16 -

STANDARD ✓ AMG-LINE ✗

06/'17-

STANDARD ✓ AMG-LINE ✗

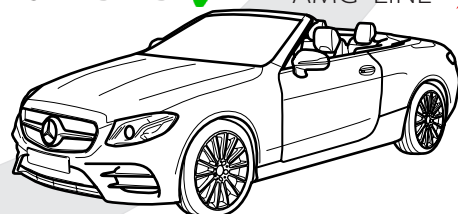

NL Belangrijke raadgevingen

Montage

- Voor de montage moet de trekhaak eerst op het voertuig gepresenteerd worden.

De belasting van een aanhangwagen en van een accessoire dat op de koppelingskogel wordt voorzien, zijn anders van aard. Voor beiden kunnen verschillende limieten van toepassing zijn. Hiervoor verwijzen we naar het instructieboekje van de wagen of naar uw concessiehouder.

FR Recommandations importantes

Montage

- Présenter l'attelage sous le véhicule avant d'effectuer le montage.

La charge d'une remorque ou d'un accessoire prévue sur la boule d'attelage, est de nature diverse. Pour ces deux éléments, il peut y avoir des limites d'utilisation. Nous vous recommandons de vous référer à votre livret d'instructions ou de vous renseigner chez votre concessionnaire.

GB General instructions

Fitting

- Present the towbar under the car first to check if all points are right.

The load of a trailer and of an accessory fitted on the towing ball are of a different nature. Different limits may apply to both. For this matter, we refer to the instruction manual of the vehicle or we advise you to contact your concessionaire.

D Wichtige ratschläge

Montage

- Erst die Anhängerkupplung und das Fahrzeug kontrollieren, danach montieren.

Die Belastung eines Anhängers und eines Zubehörs, die man auf einer Kupplungskugel voraussieht, ist wesentlich anders. Für beide gilt, dass diese unterschiedlich begrenzt sein können. Deswegen möchten wir verweisen auf die Bedienungsanleitung des Fahrzeugs oder auf Ihren Vertragshändler.

E Instrucciones generales

Montaje

- Presentar el enganche debajo del vehículo antes de realizar el montaje.

La carga de un remolque y un accesorio montado en una bola de remolque son de una naturaleza diferente. Se pueden aplicar diferentes límites a ambos. Para este asunto, nos referimos al manual de instrucciones del vehículo o le recomendamos que contacte a su distribuidor.

DK Generelle instruktioner

Montering

- Præsenter trækstangen under bilen først for at kontrollere, om alle punkter er rigtige.

Belastningen af en trailer og af tilbehør tilkoblet anhængertrækket er forskellige. Der kan være forskellige begrænsninger på begge. I disse tilfælde henviser vi til bilens manual, eller anbefaler dig at kontakte bilforhandleren

IT Consigli importanti



Montaggio

- In primo luogo, presentare la struttura sotto l'automobile per verificare che tutti i punti di attacco coincidano.

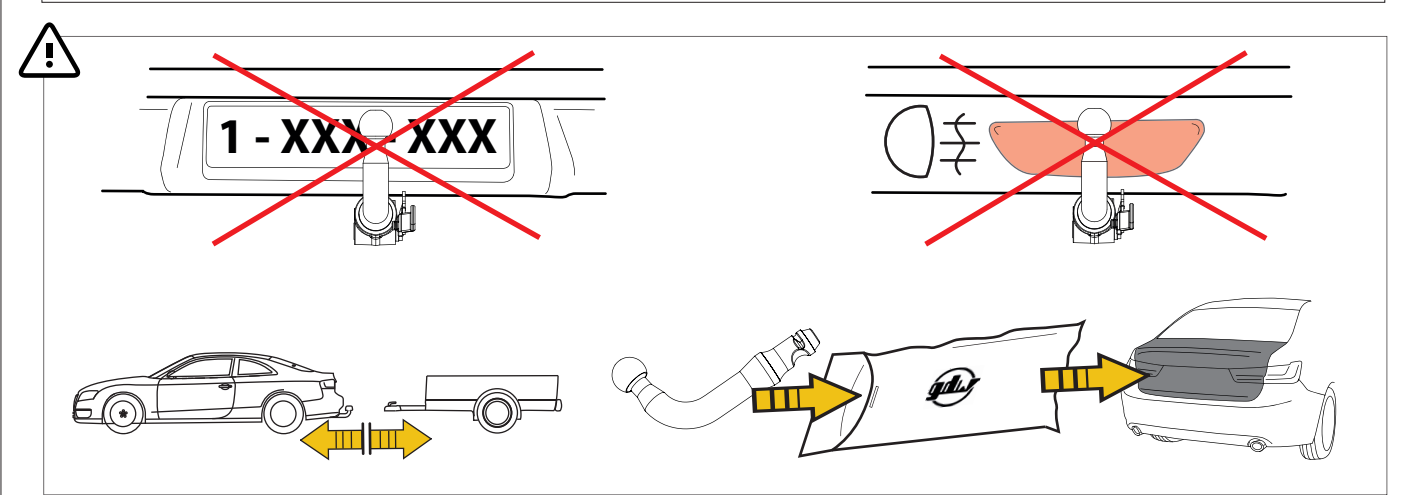
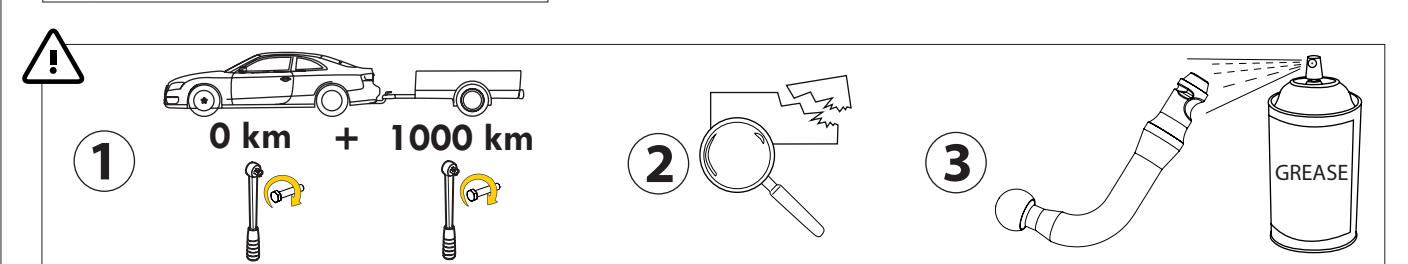
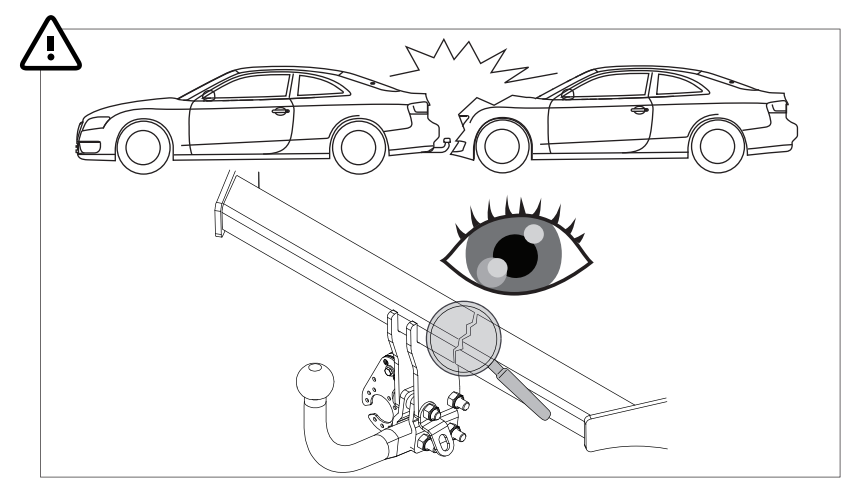
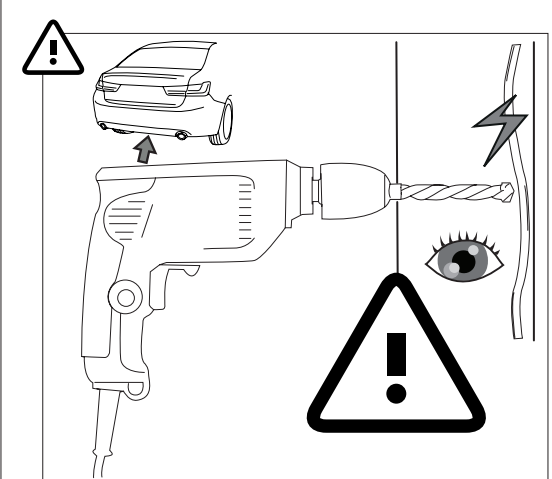
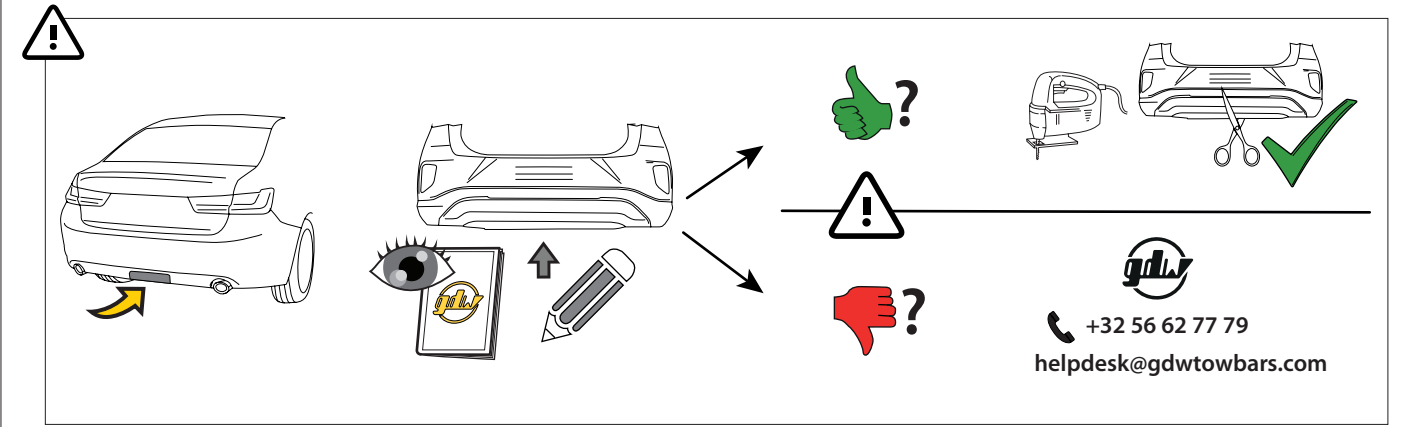
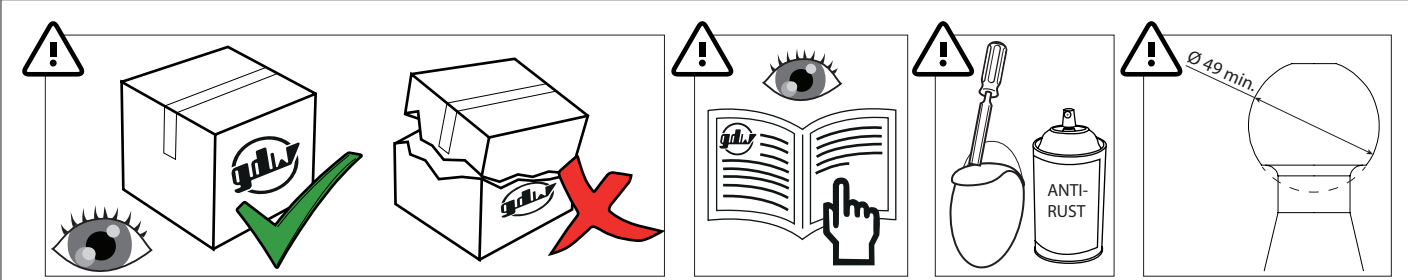
La massa rimorchiabile del veicolo potrebbe essere diversa dal valore riportato sul documento del gancio di traino. Per questo motivo, vi invitiamo a consultare sempre la carta di circolazione del veicolo (Pos. O.1) o a rivolgervi alla vostro concessionario di fiducia



MADE BY 	D 11,90	F	E6
BELGIUM	S 115	EC-N° 55R-01 1589	
REF N° 2187T60		SERIAL N° XXXX	
DESCRIPTION Mercedes C W205 + S205 + C205 + A205 Mercedes E W213 + S213 + C238 + A238			

$$D = \frac{\text{max kg} \times \text{max kg}}{\text{max kg} + \text{max kg}} \times 0.00981 \leq 11,90 \text{ kN}$$

$$S = \begin{matrix} \leq 115 \text{ kg} & \leq 2100 \text{ kg} \end{matrix}$$

See the Certificate Of Conformity (COC) of your vehicle or contact your dealer to verify the max. trailer weight of your car!



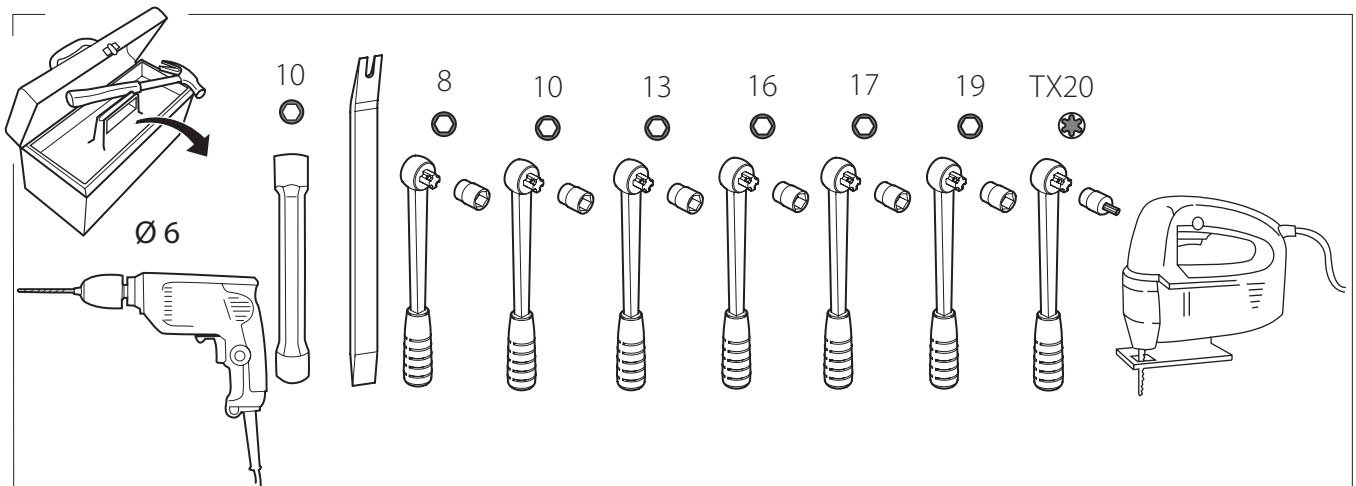
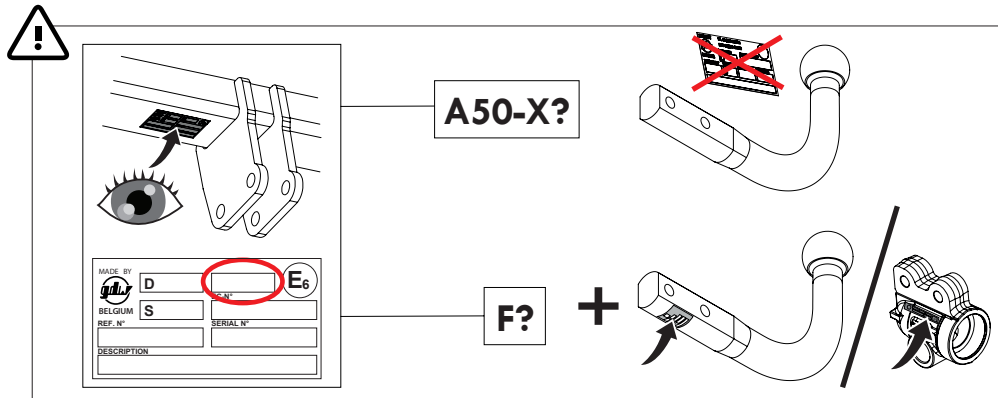
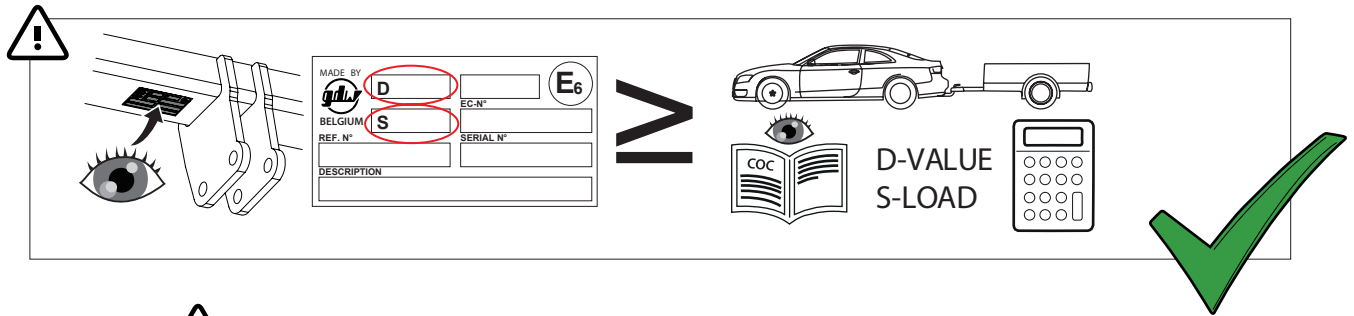
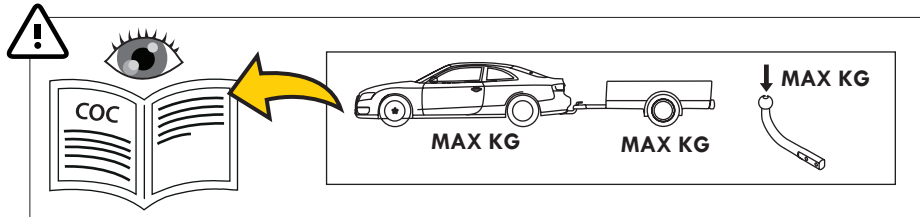









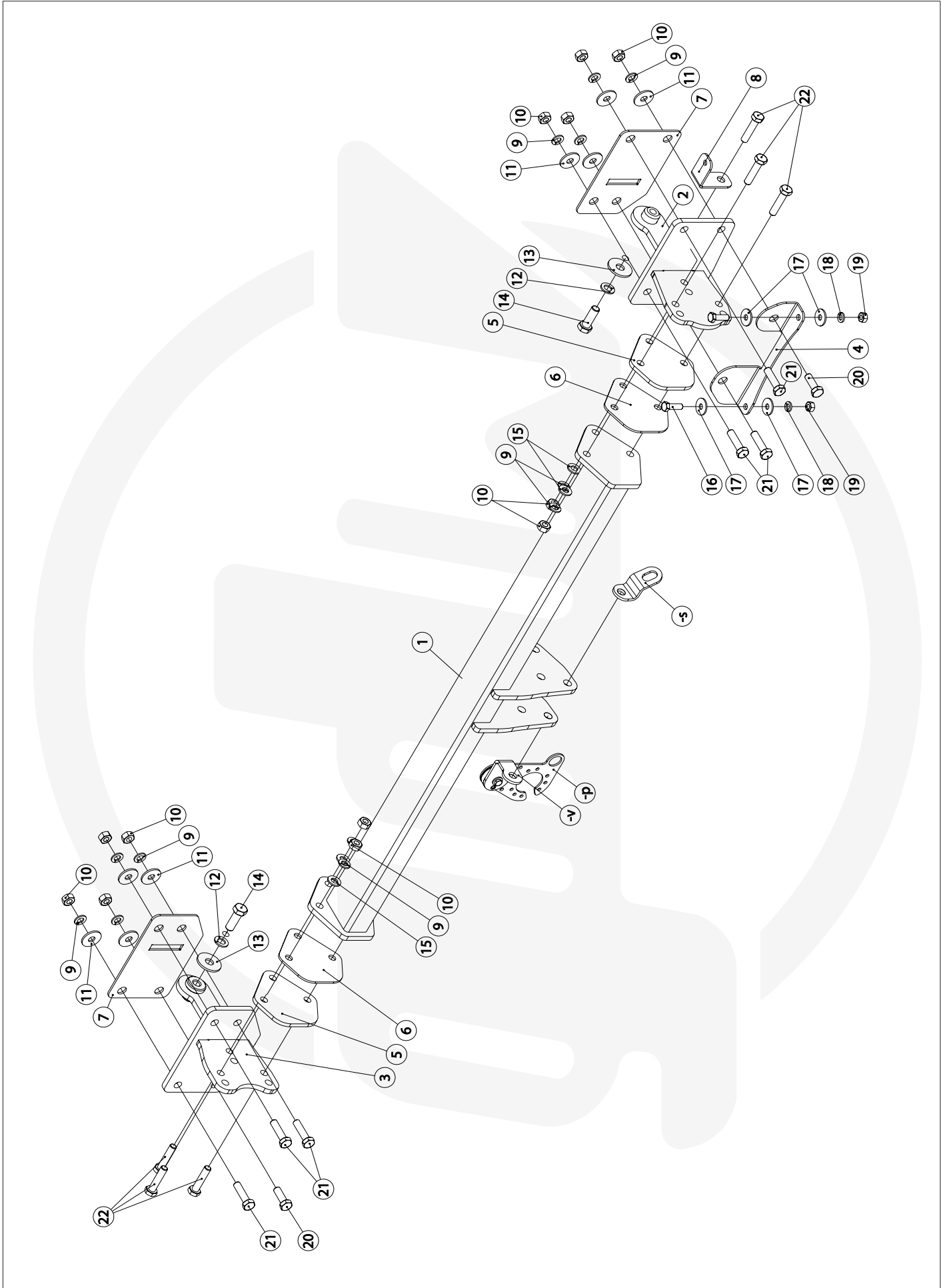

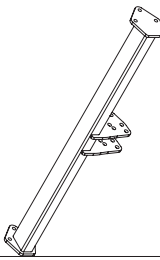
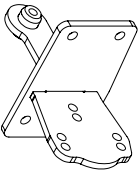
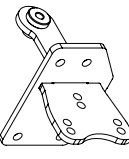
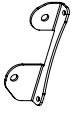

helpdesk@gdwtowbars.com















+32 56 62 77 79



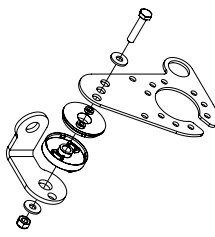



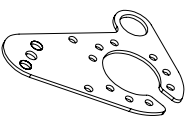

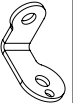

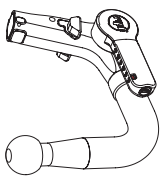
Monday	08:00 - 12:00	12:30 - 16:30
Tuesday	08:00 - 12:00	12:30 - 16:30
Wednesday	08:00 - 12:00	12:30 - 16:30
Thursday	08:00 - 12:00	12:30 - 16:30
Friday	08:00 - 12:00	12:30 - 15:30

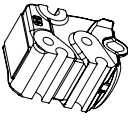

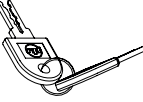

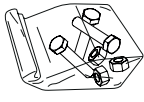
1		X1	GDW REF. 2187160
2		X1	GDW REF. 2
3		X1	GDW REF. 3
4		X1	GDW REF. 4
5		X2	GDW REF. 5 (6 MM)
6		X2	GDW REF. 6 (3 MM)
7		X2	GDW REF. 7
8		X1	GDW REF. 2187160-100 (ONLY FOR PLUG-IN HYBRID)
9		X14	DIN128A-M10
10		X14	DIN934-M10
11		X8	DIN9021-M10-ELVZ
12		X2	DIN128A-M12
13		X2	DIN9021-M12-ELVZ
14		X2	DIN961-M12X35X1.5
15		X6	DIN125-A10-14OHV-ELVZ

16		X2	DIN933-M8X25
17		X4	DIN9021-M8-ELVZ
18		X2	DIN128A-M8
19		X2	DIN934-M8
20		X2	DIN933-M10X30
21		X6	DIN933-M10X40
22		X6	DIN933-M10X45
-5		X1	GDW REF. 900.053
-P		X1	GDW REF. P40
↳		X1	DIN985-M6
↳		X2	6,2 X 15,4 X 1,6 (NYLON)
↳		X1	GDW REF. 718.16.002
↳		X1	GDW REF. 718.16.003
↳		X1	GDW REF. 908.094
↳		X1	DIN933-M6 X 30
↳		X1	GDW REF. 5

Geleverd met - Livré avec - Delivered with Geliefert mit - Elementos adjuntos - Leverages med		X1	GDW REF. 960.V0808
	↳ 	X1	GDW REF. 740.200
		X1	GDW REF. 912.003
	↳ 	X1	GDW REF. 740.112
	↳ 	X1	GDW REF. 740.111
		X1	GDW REF. 740.12X X= LAST NUMBER ON KEY
		X1	GDW REF. 718.15.001
		X1	GDW REF. SYST60-10
	↳ 	X3	DIN931-M12X110-8.8
	↳ 	X3	DIN128A-M12
	↳ 	X6	DIN125A-M12
	↳ 	X3	DIN934-M12

1

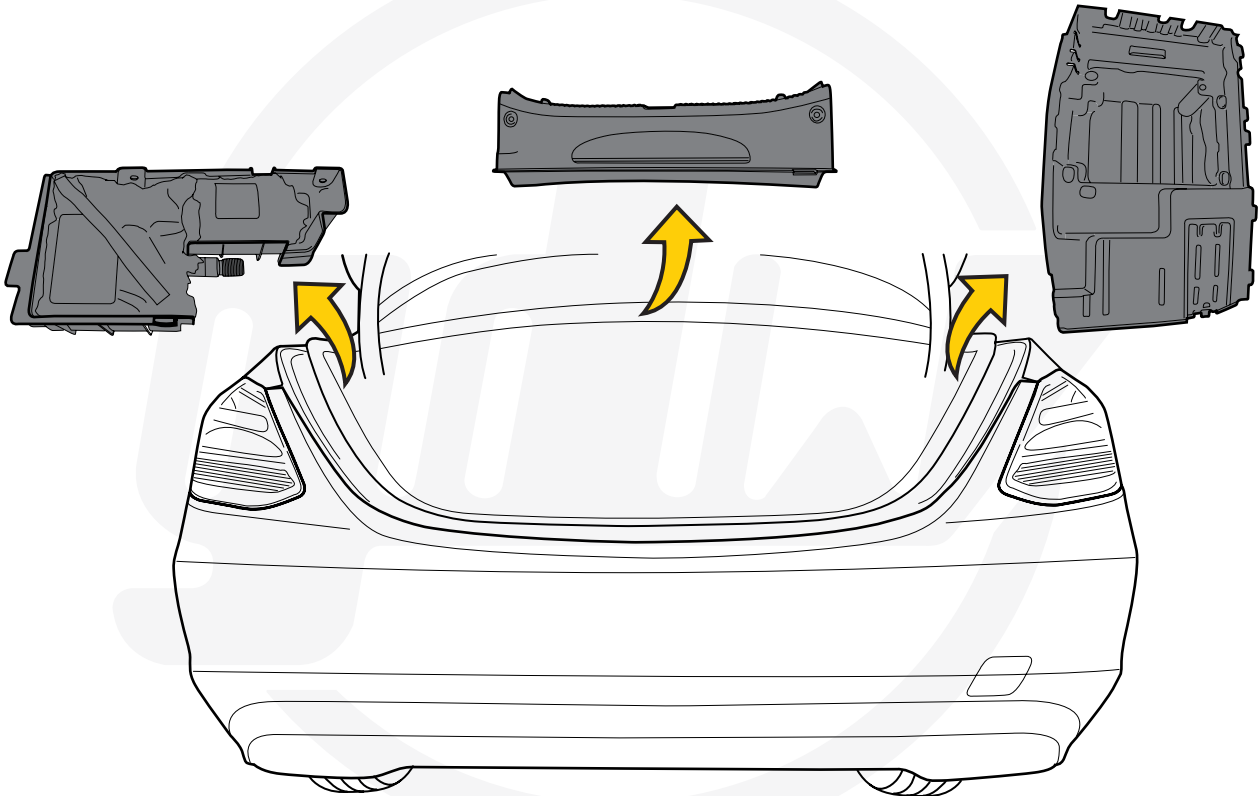

2 Only for S213 07/'20-

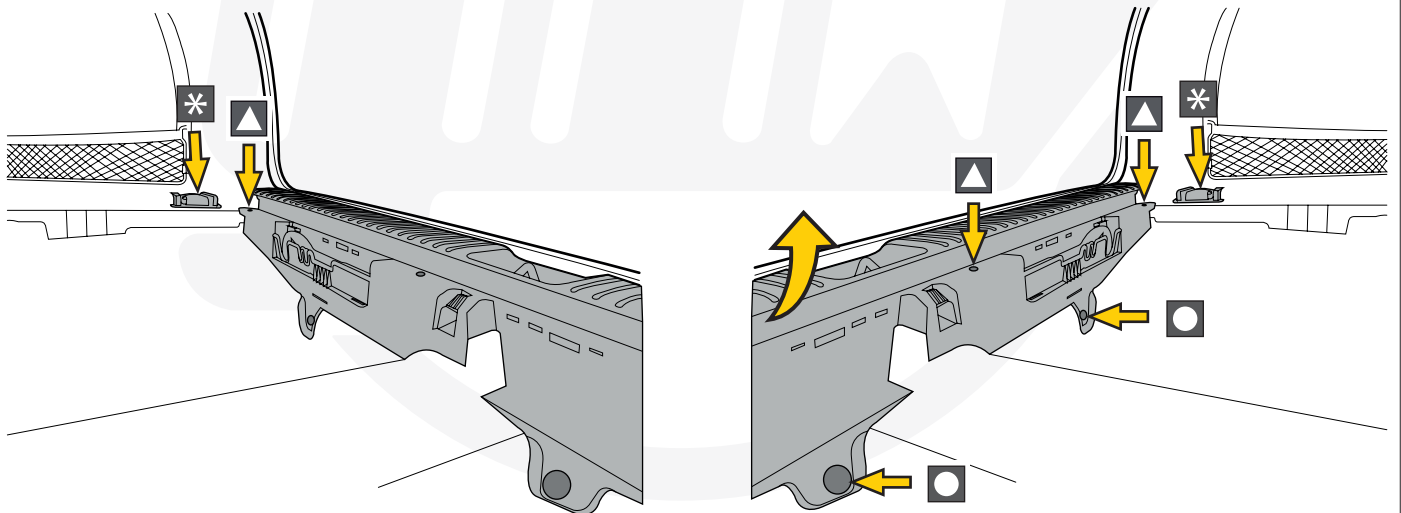
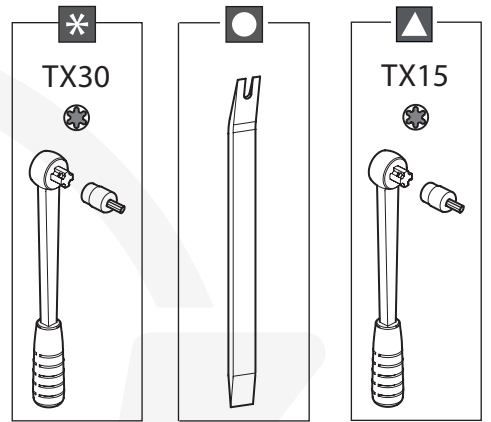
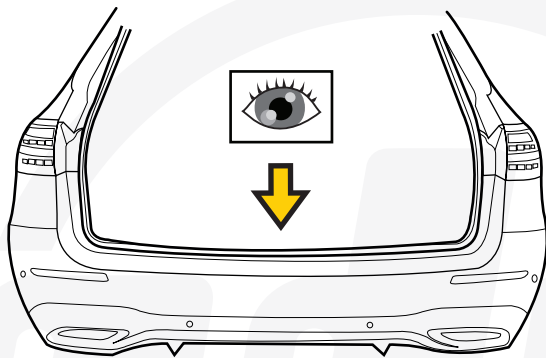

3

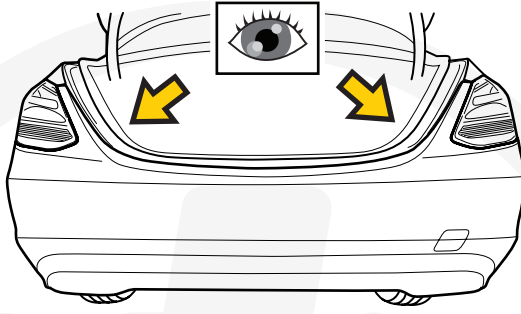

1

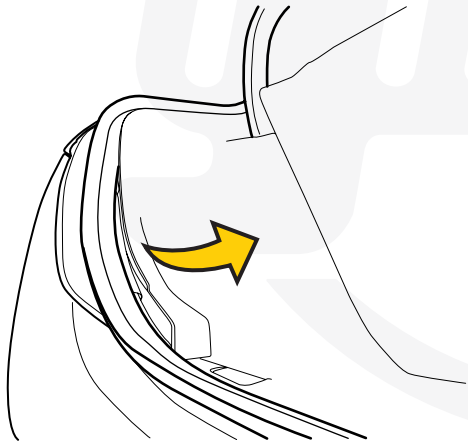

2



4

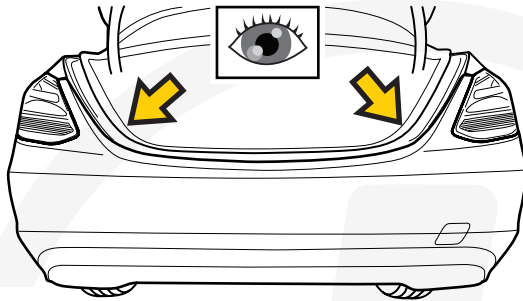

Only for W205/S205

1

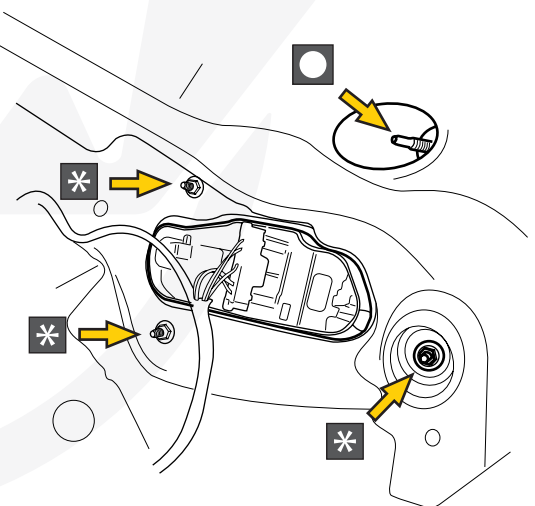
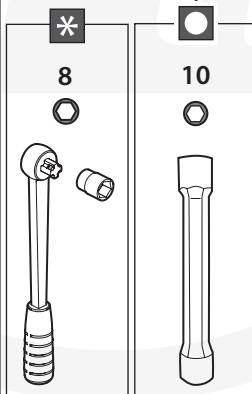
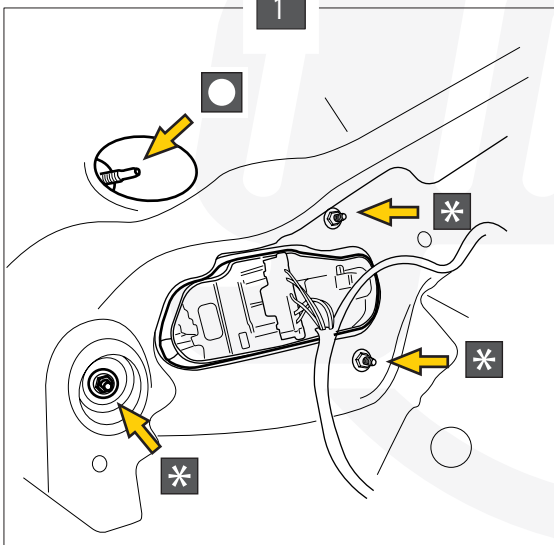

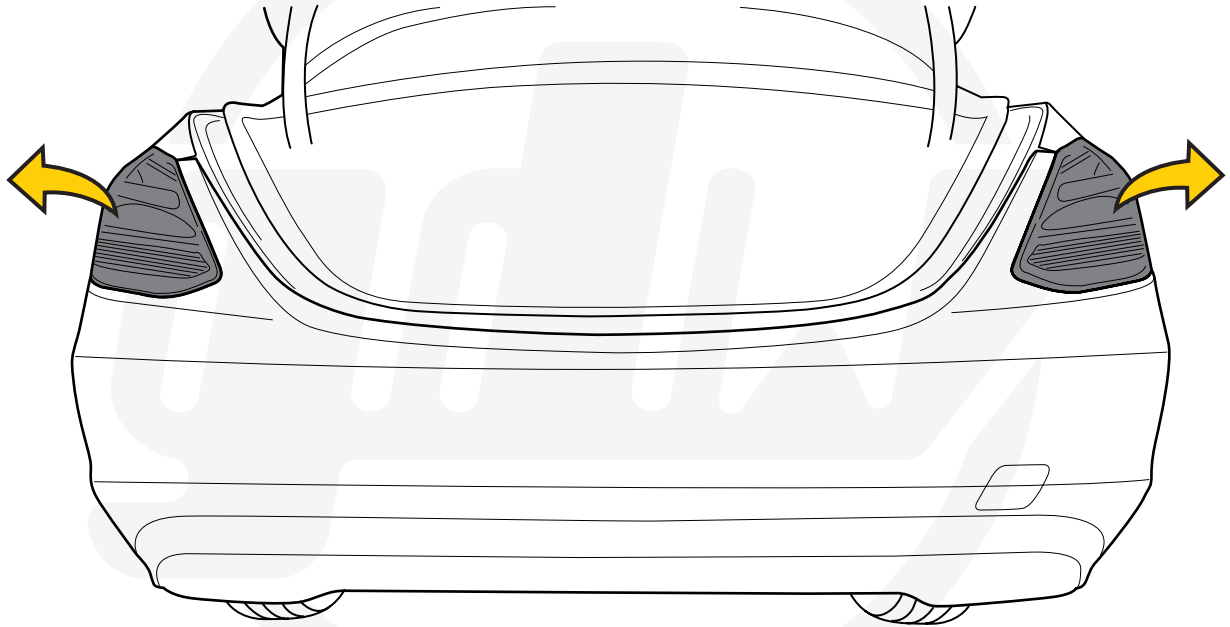

6 Only for S213 07/'20-

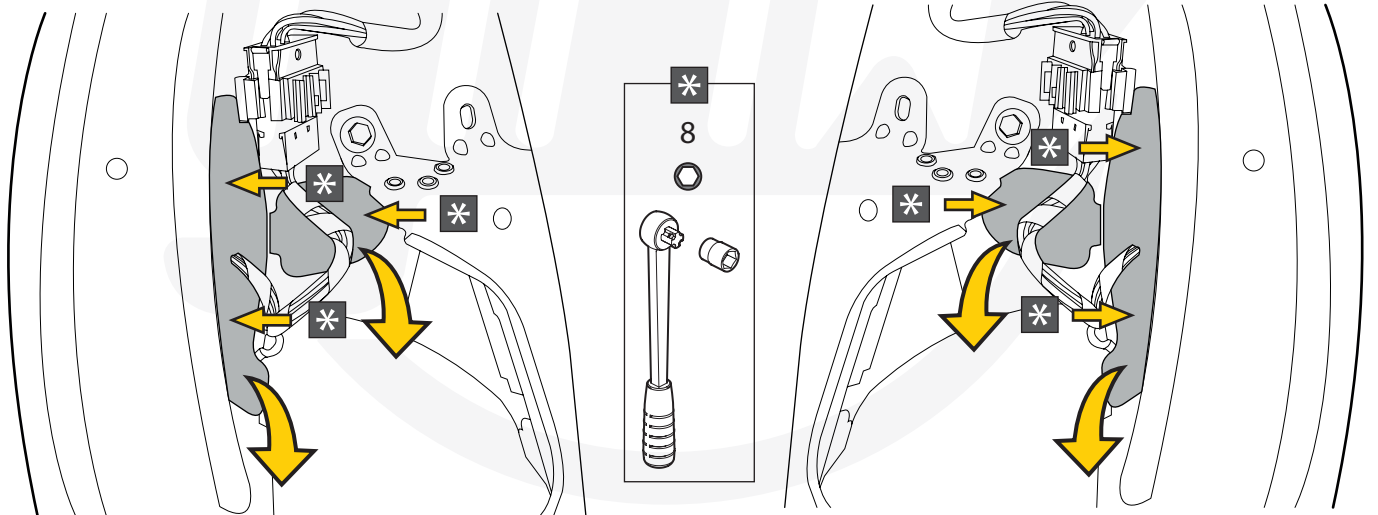
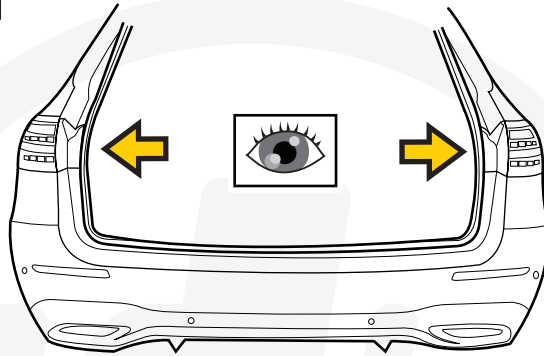

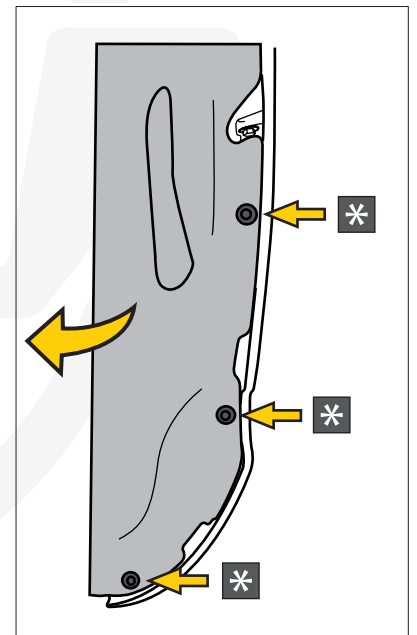
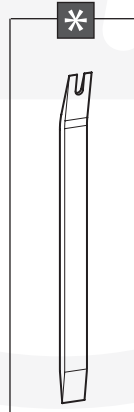
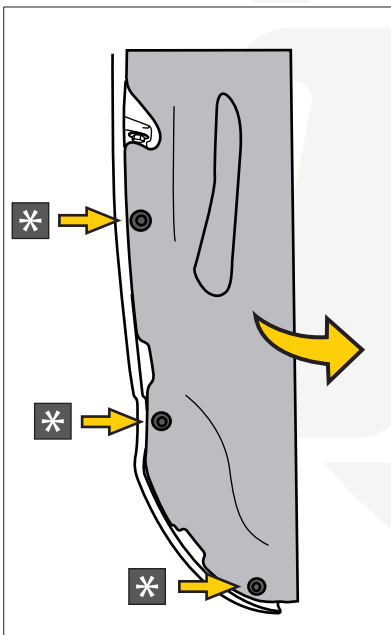
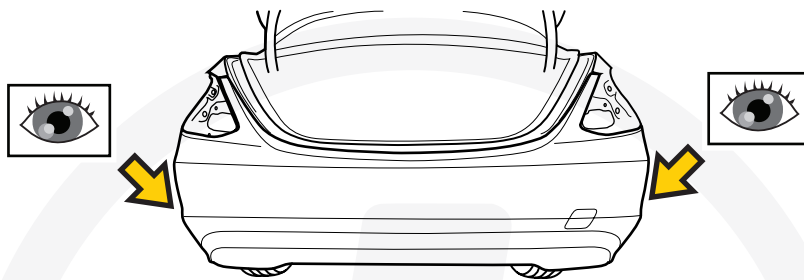
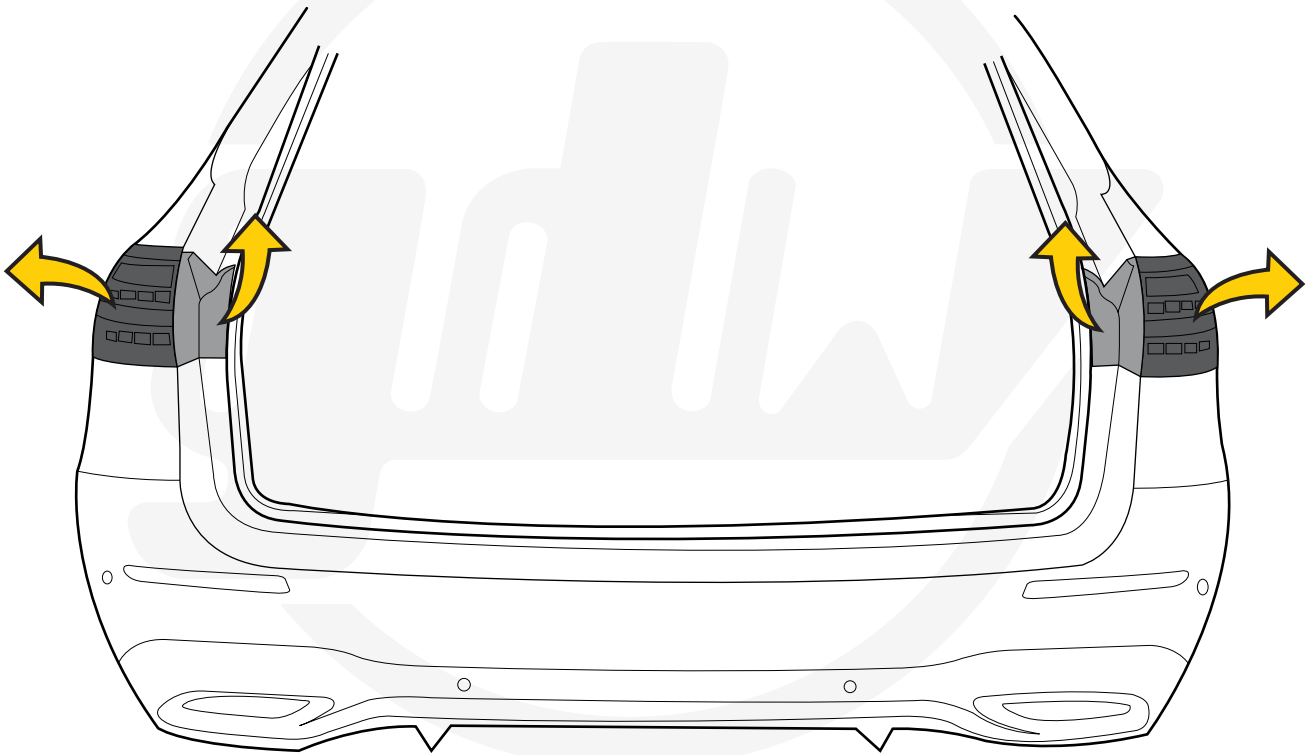

9

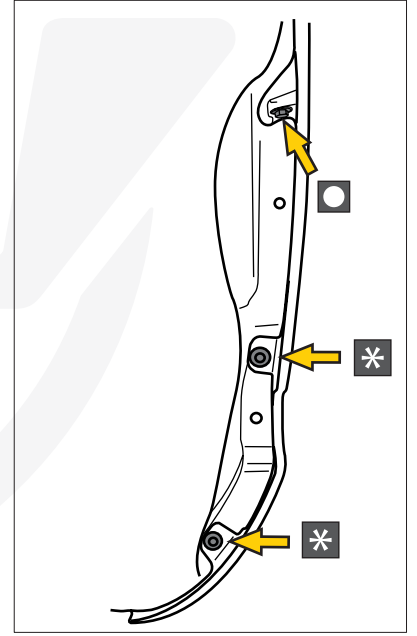
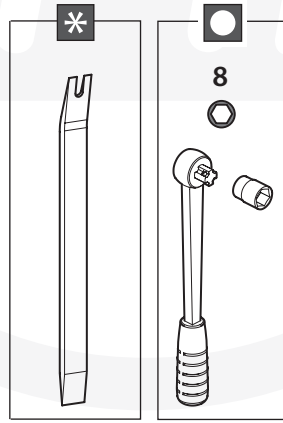
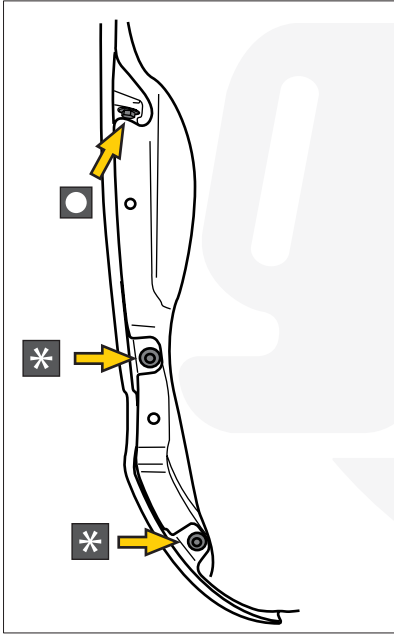
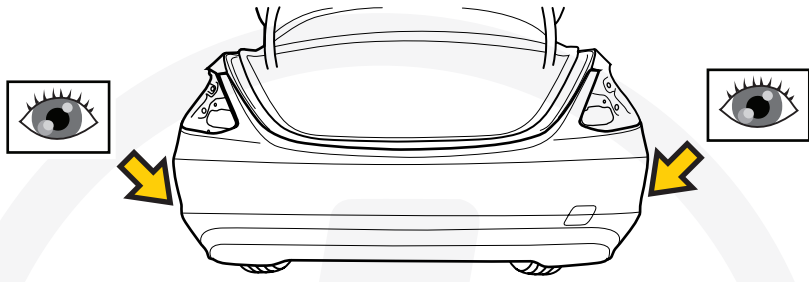

10

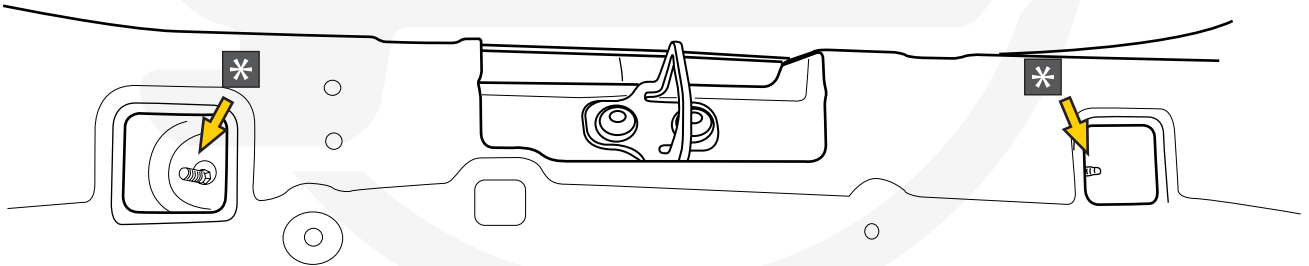
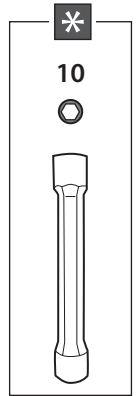
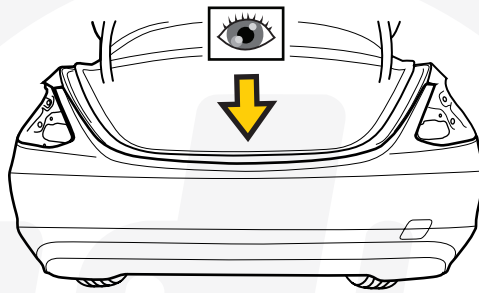

11 Only for W205/S205/C205/A205 + Cabrio

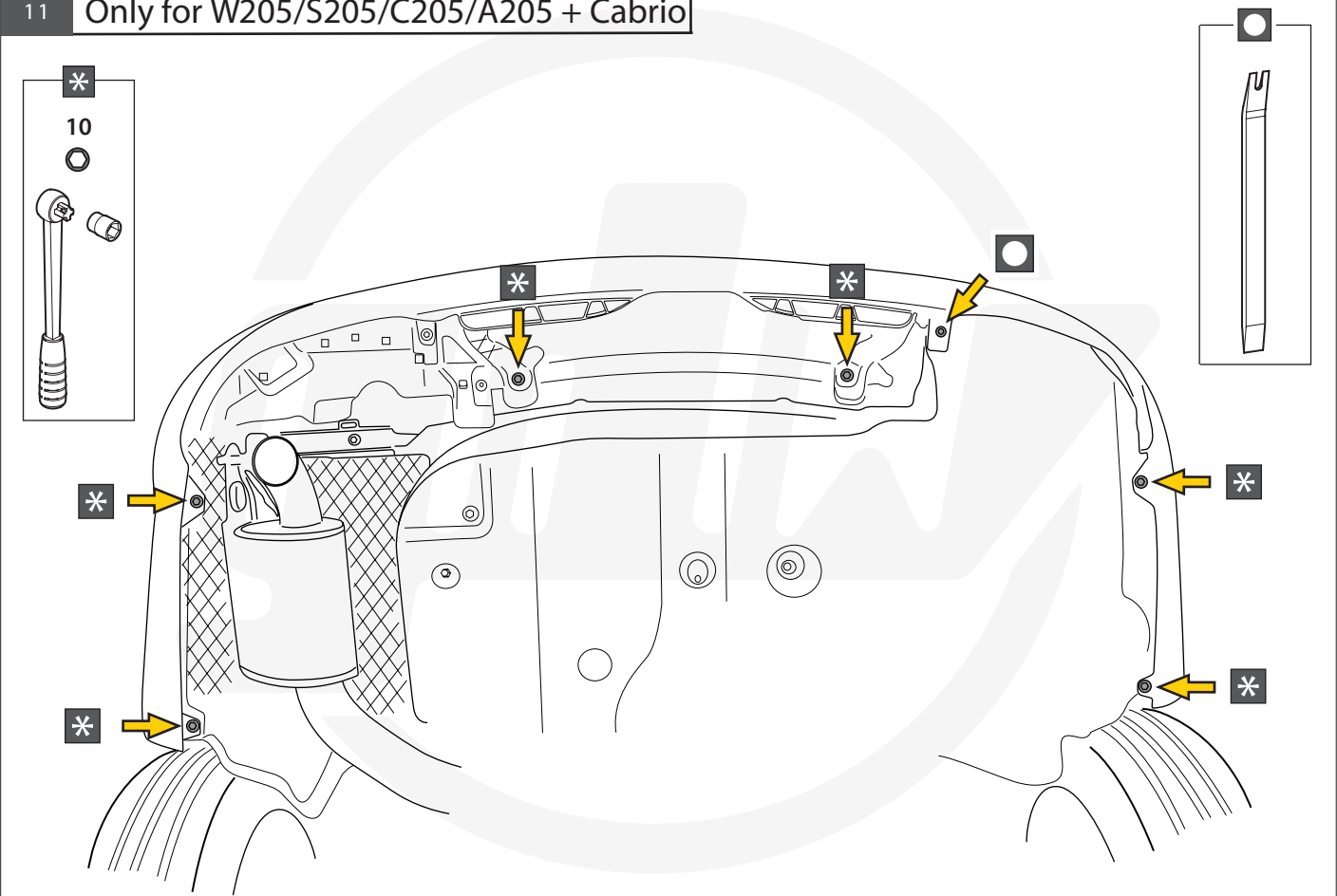

12 Only for W213 & S213

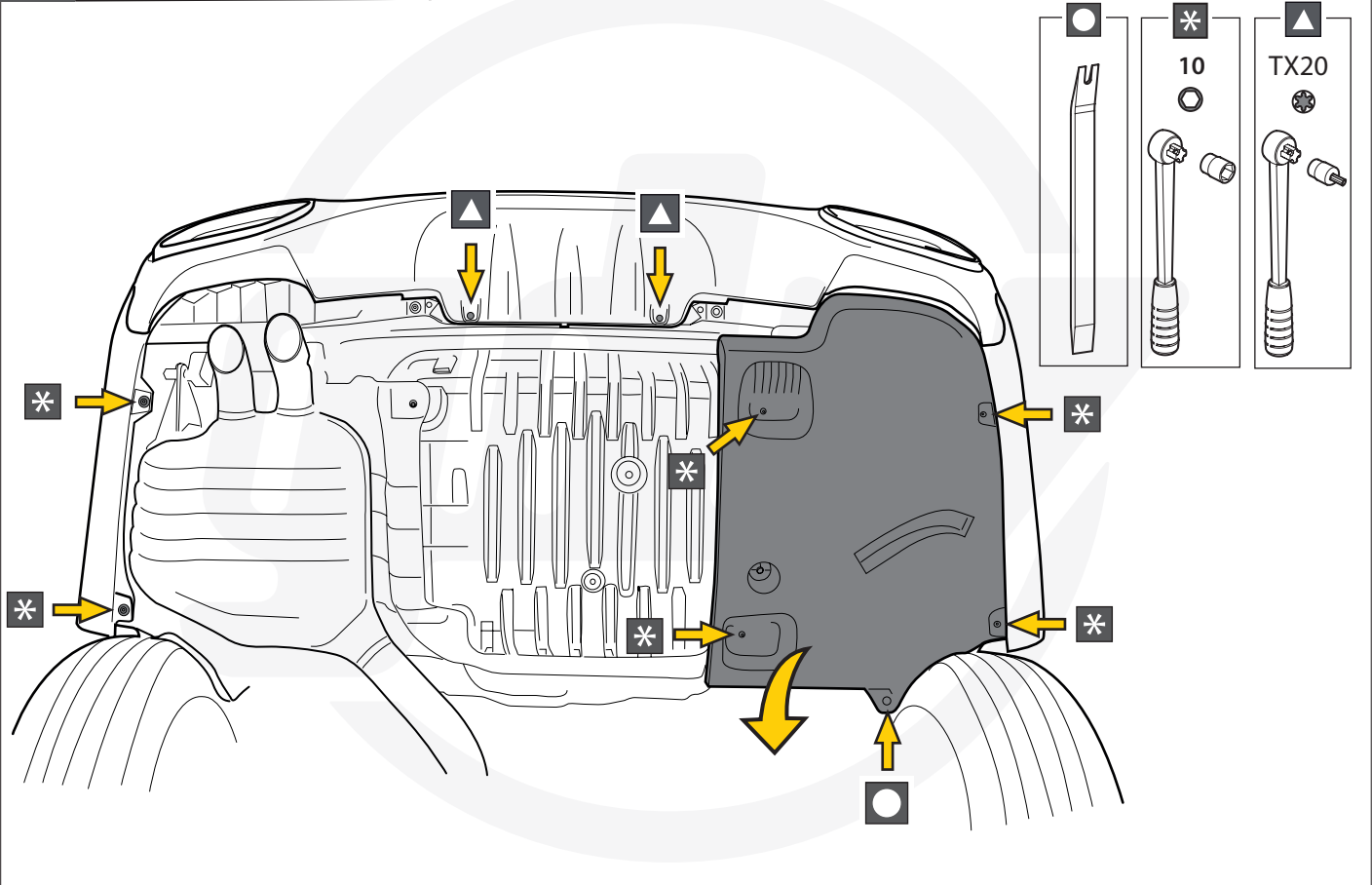

13 Only for W213 06/'20-

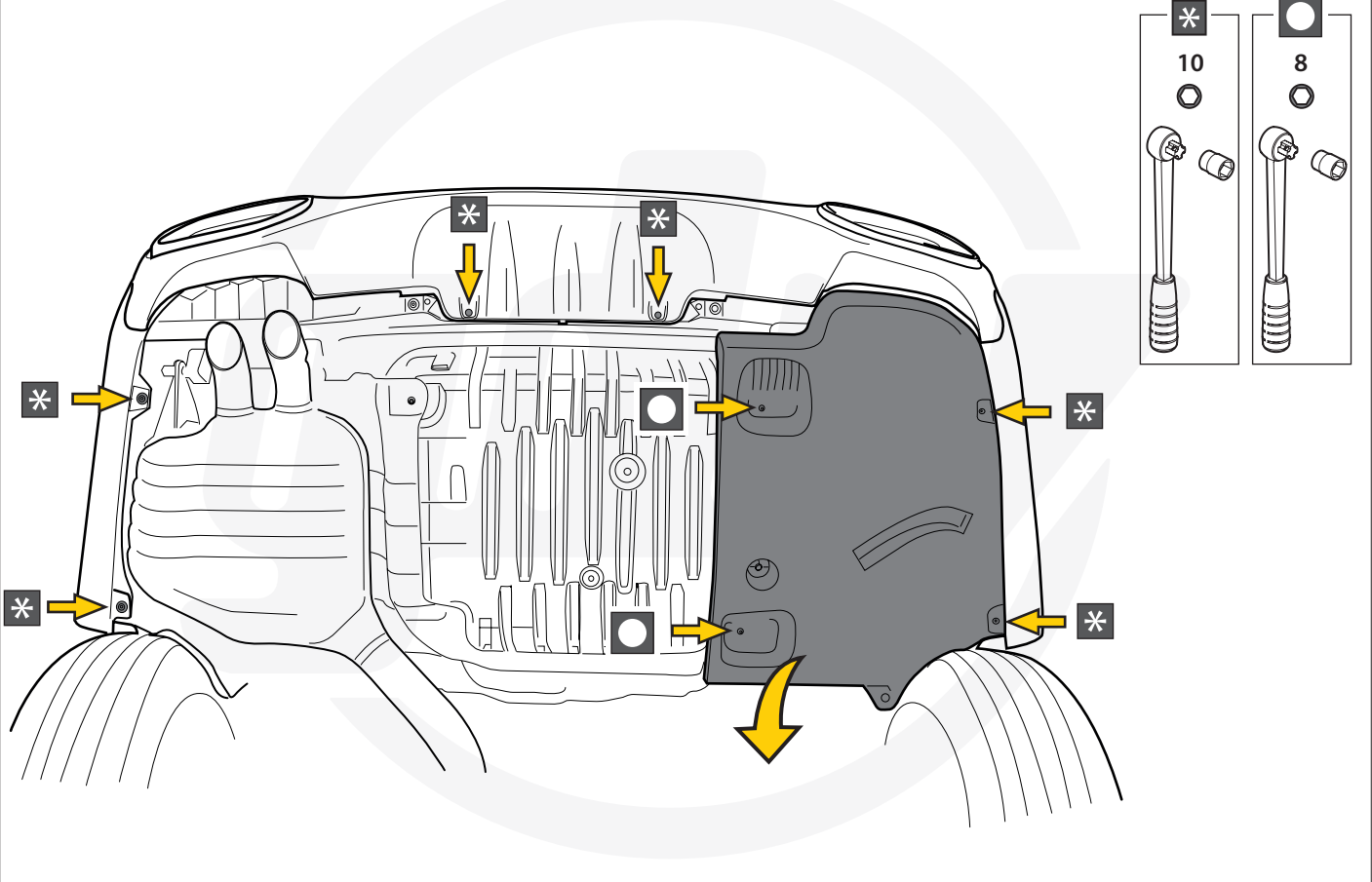

14 Only for S213 07/'20-

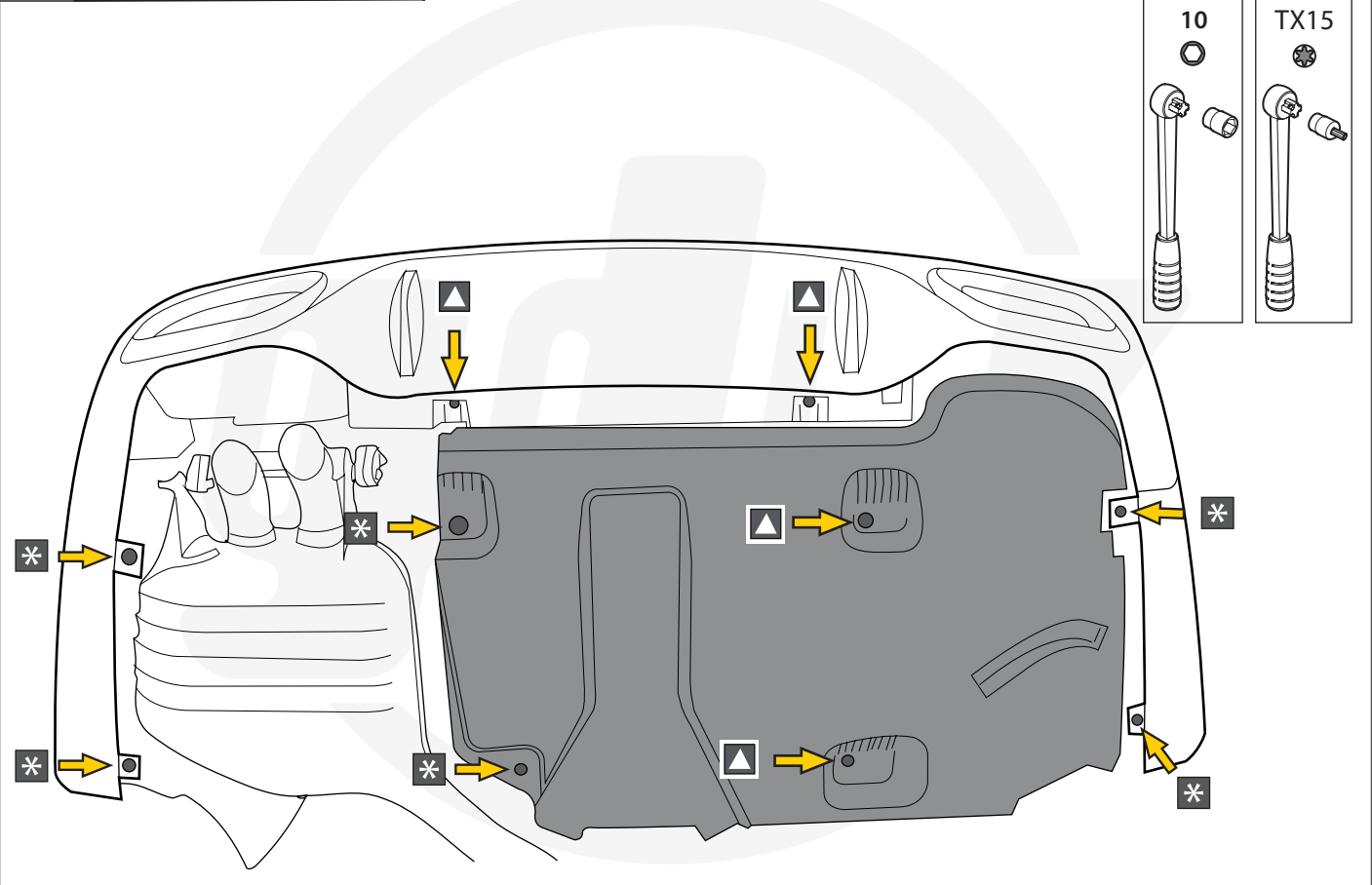

AD BLUE

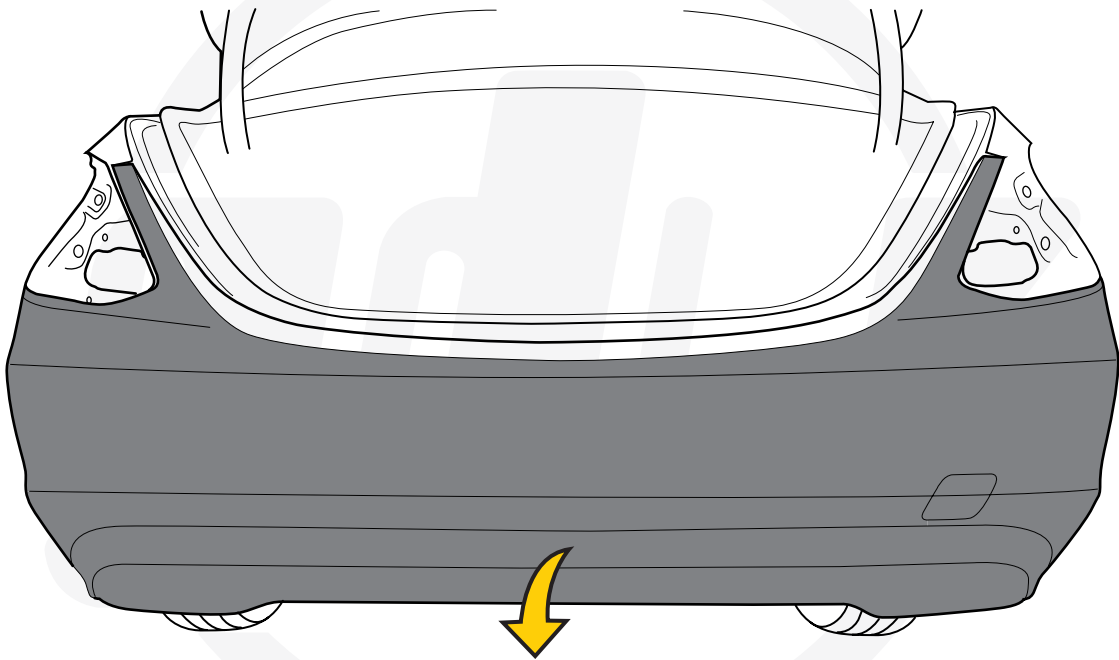
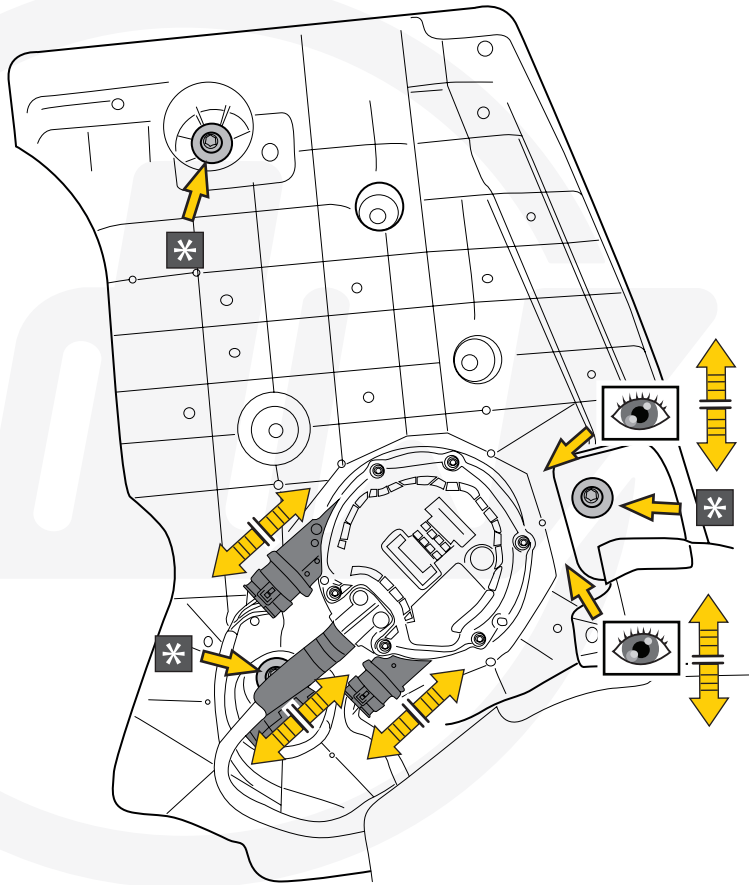
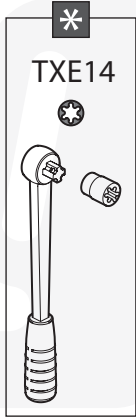

17 Only for S213 07/'20-

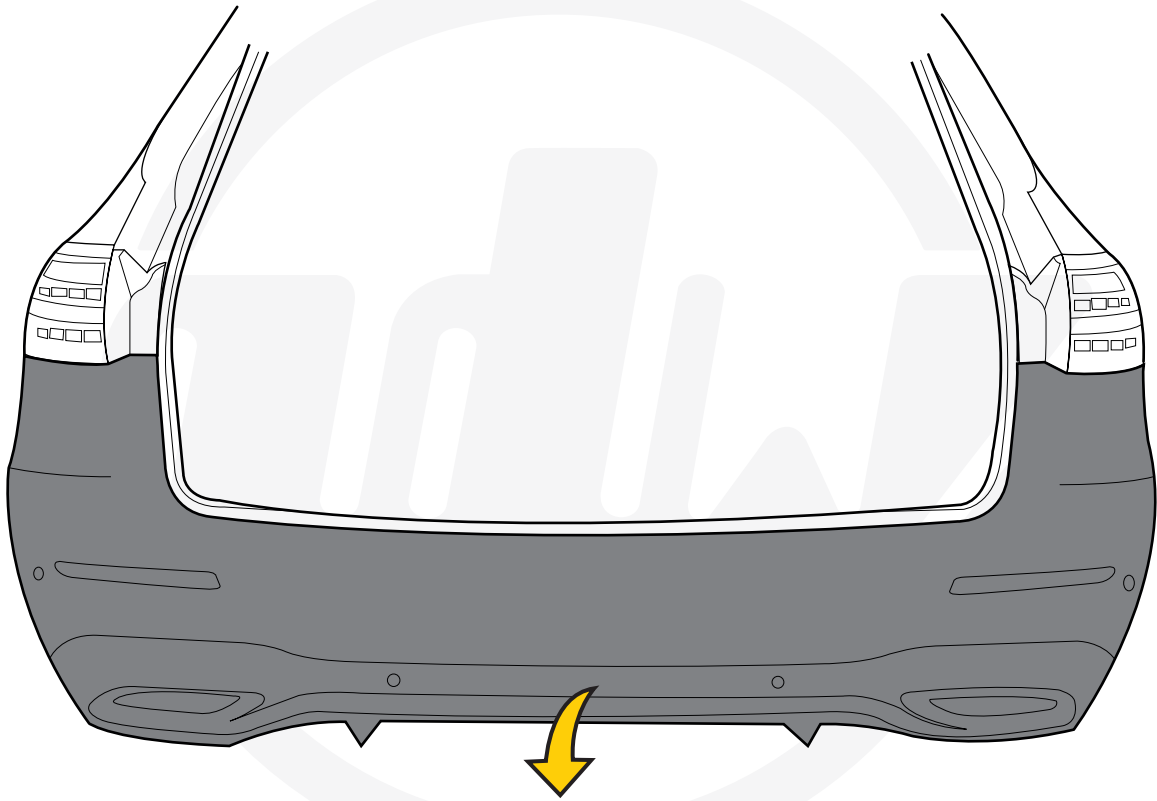

18 Only for W205/S205/C205/C238/A238

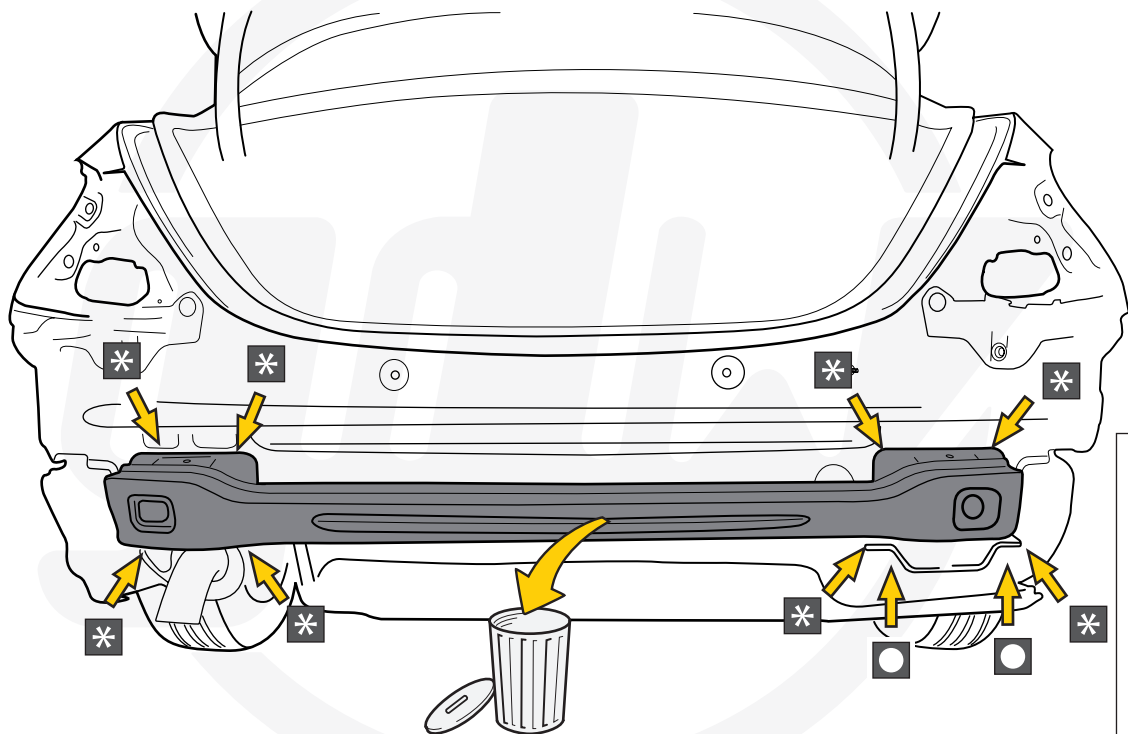

16

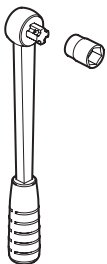

13

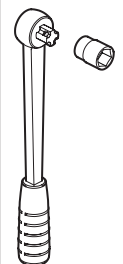

19 Only for C238/A238

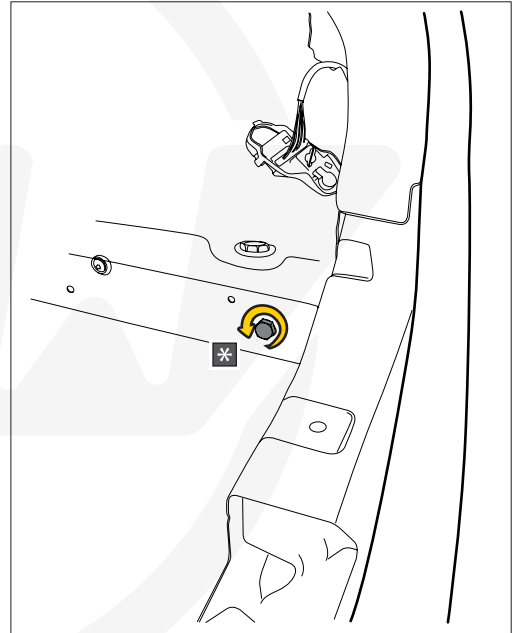
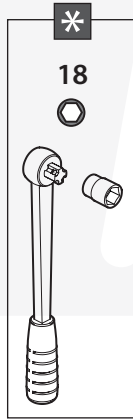
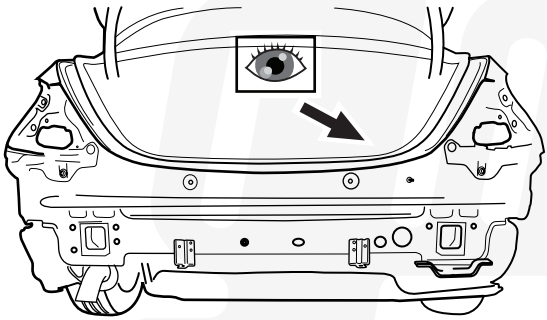

20 Only for W213 + S213 + A205 Cabrio

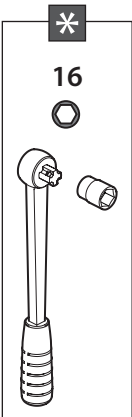
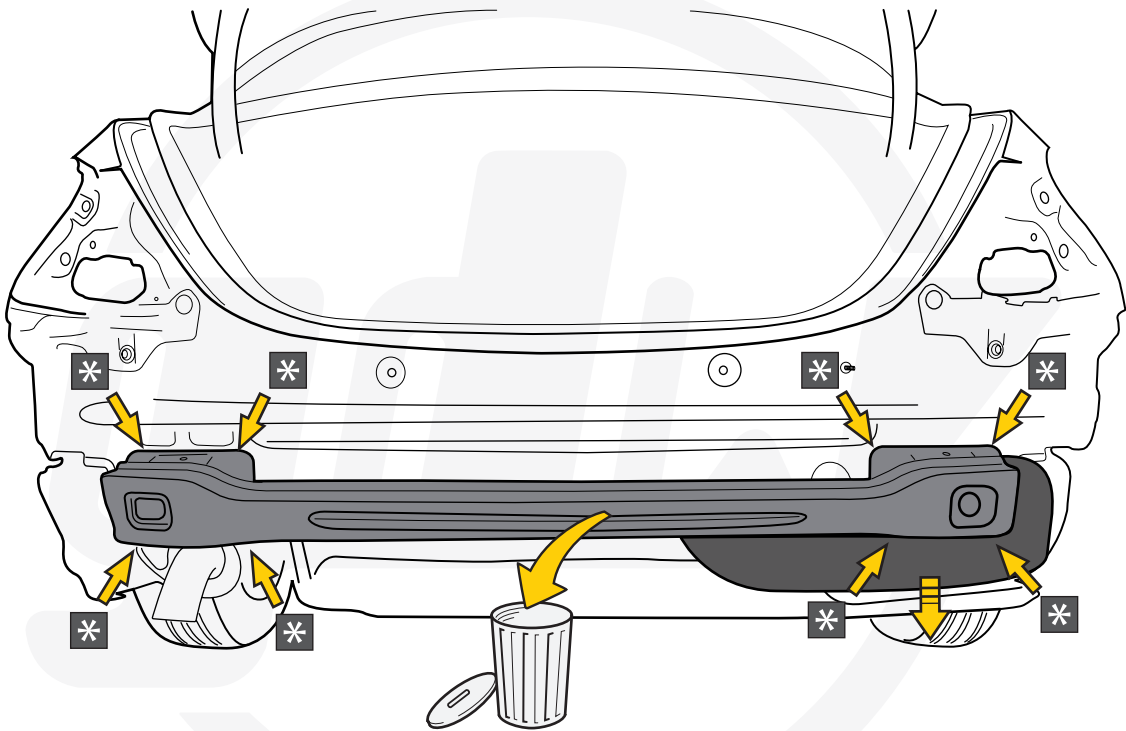

21 Only for W213 06/'20- + S213 07/'20-

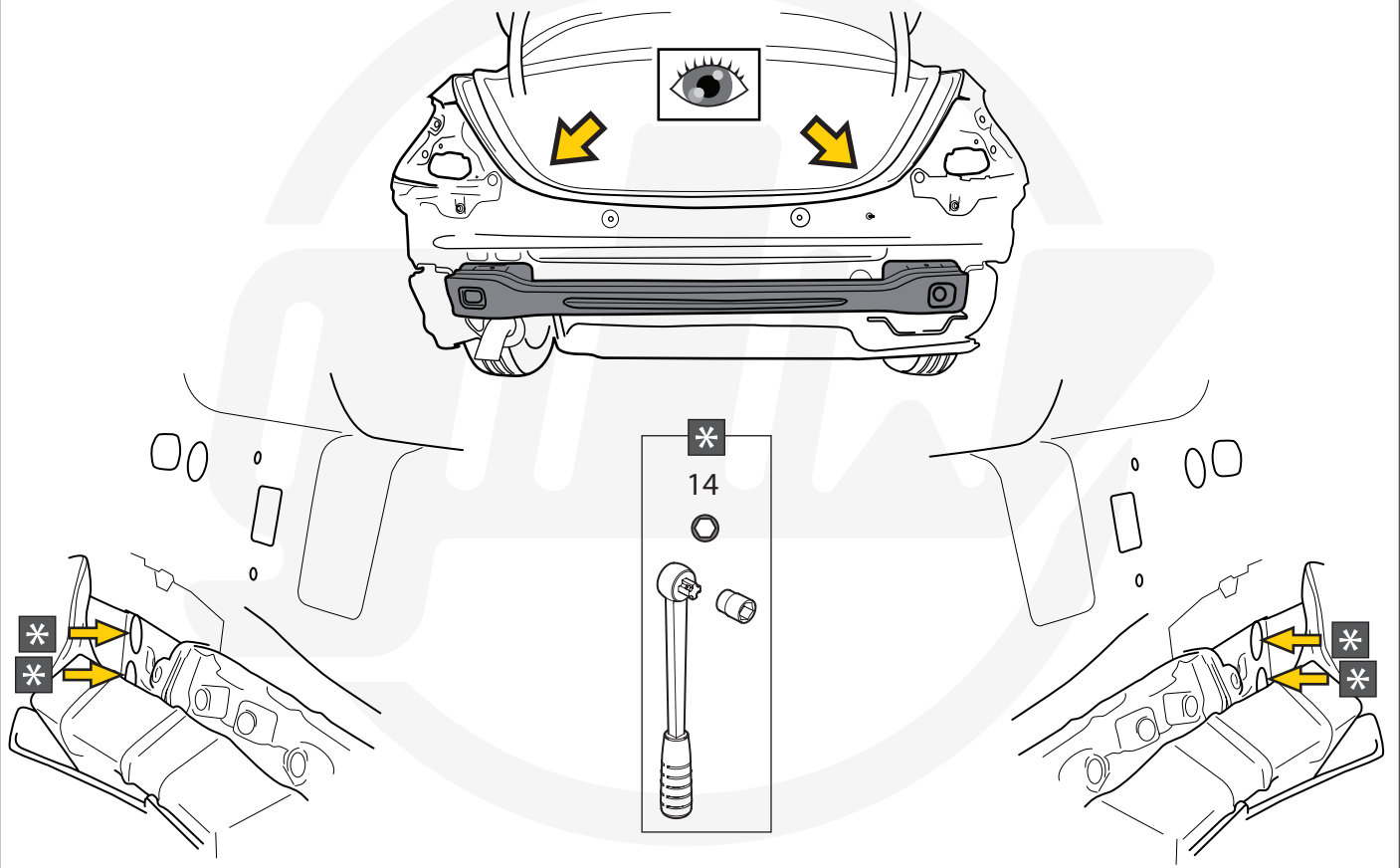

22 Only for W213 06/'20- + S213 07/'20-

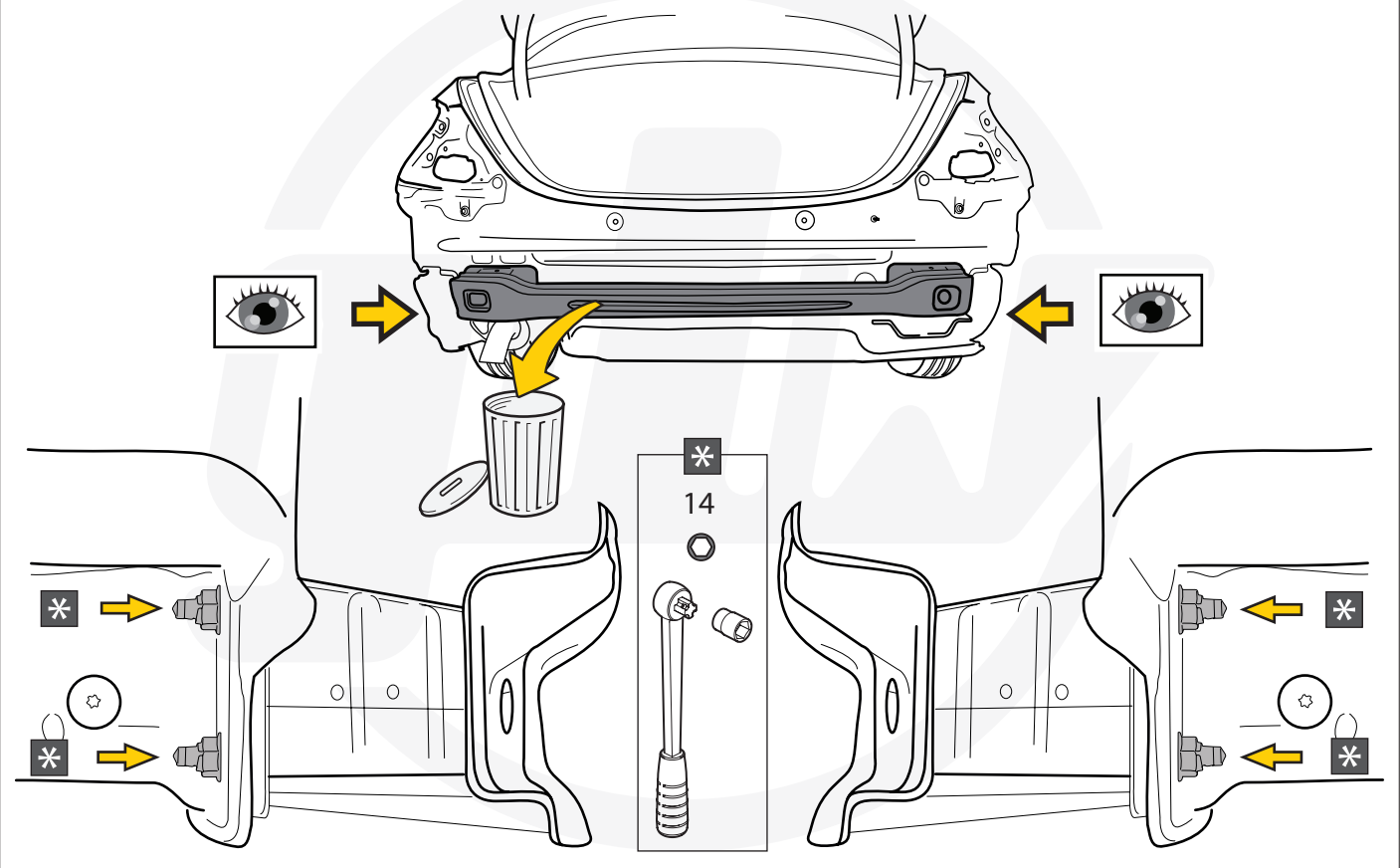

23 Only for W205/S205/C205/C238/A238

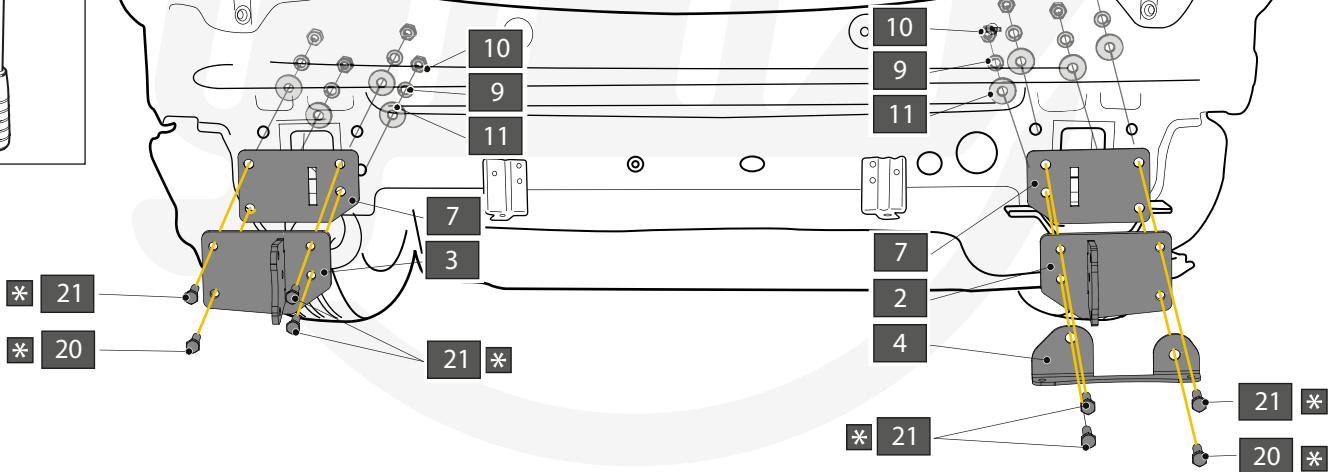
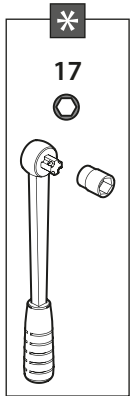

24 Only for W213 & S213

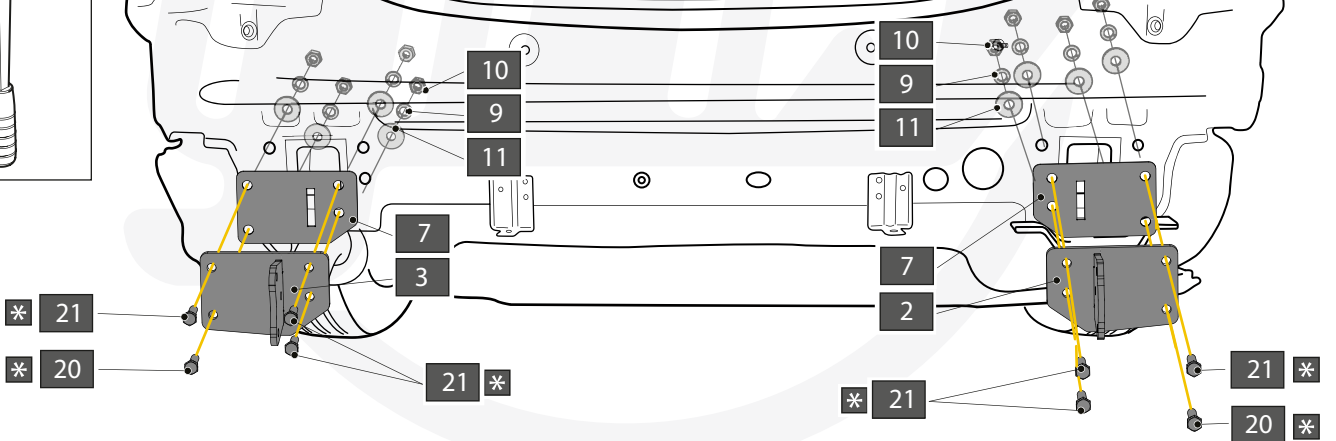
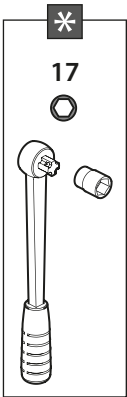

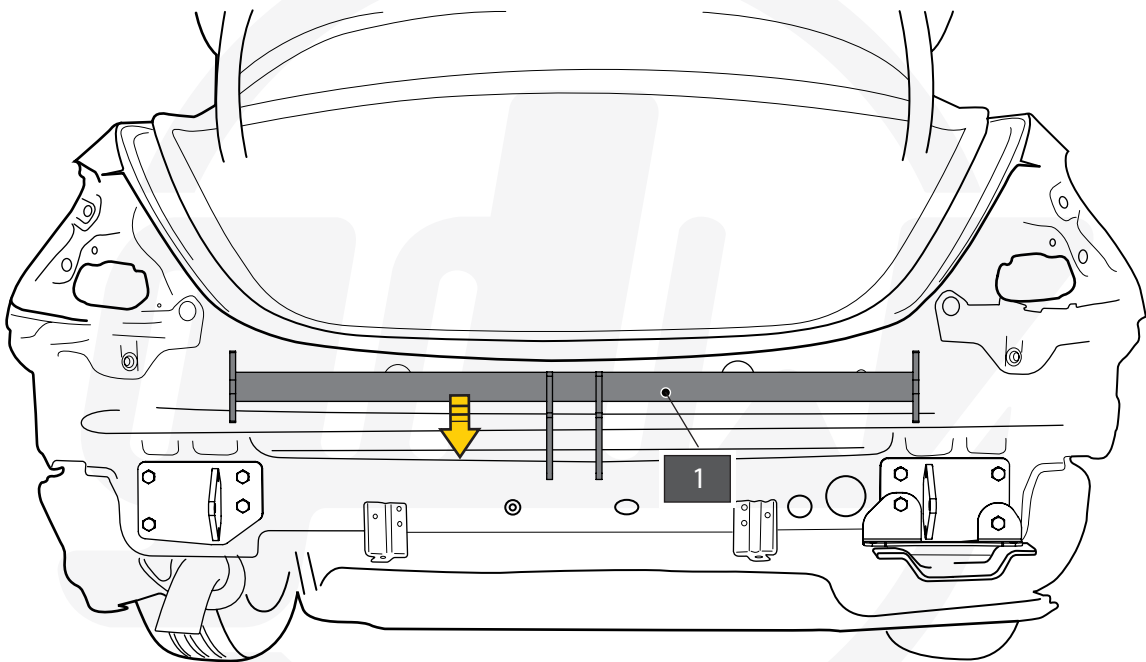
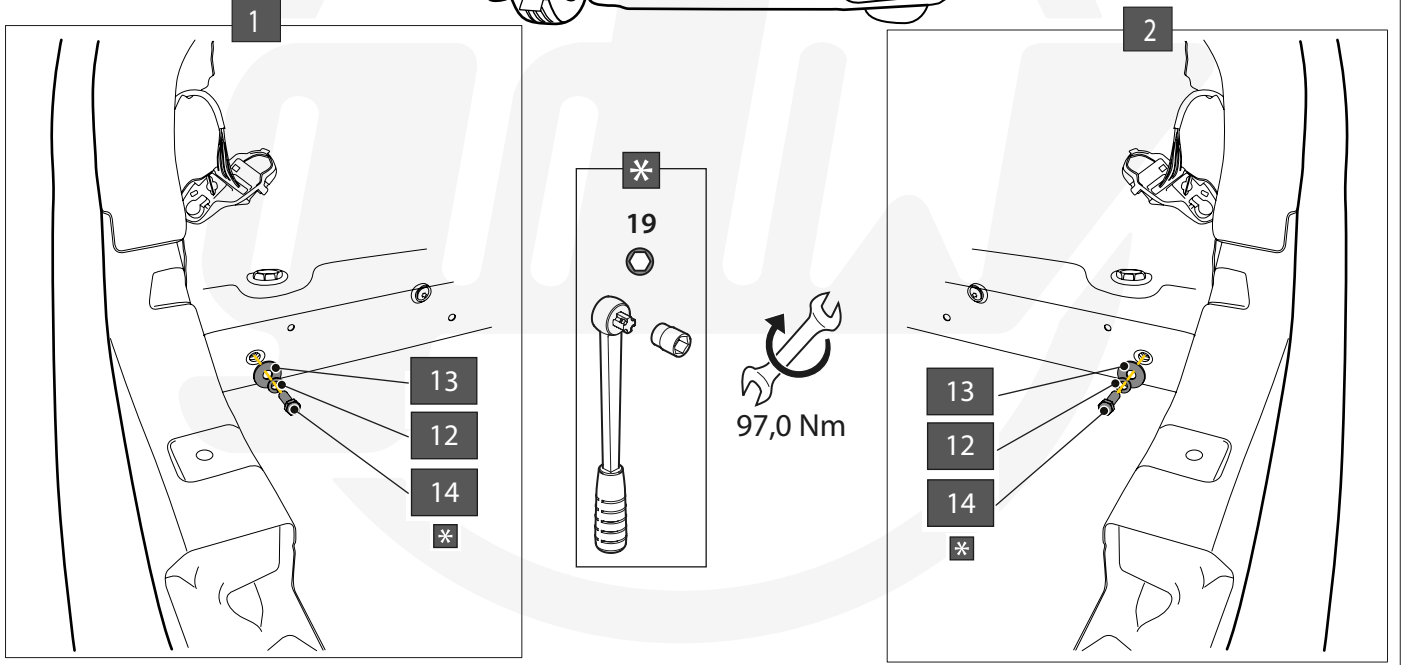
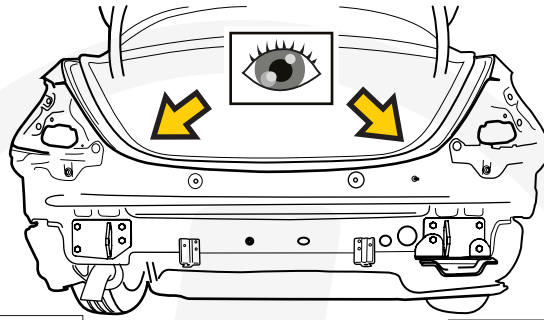

27 Only for W205/S205/A205/C205 Phase I/C238/A238

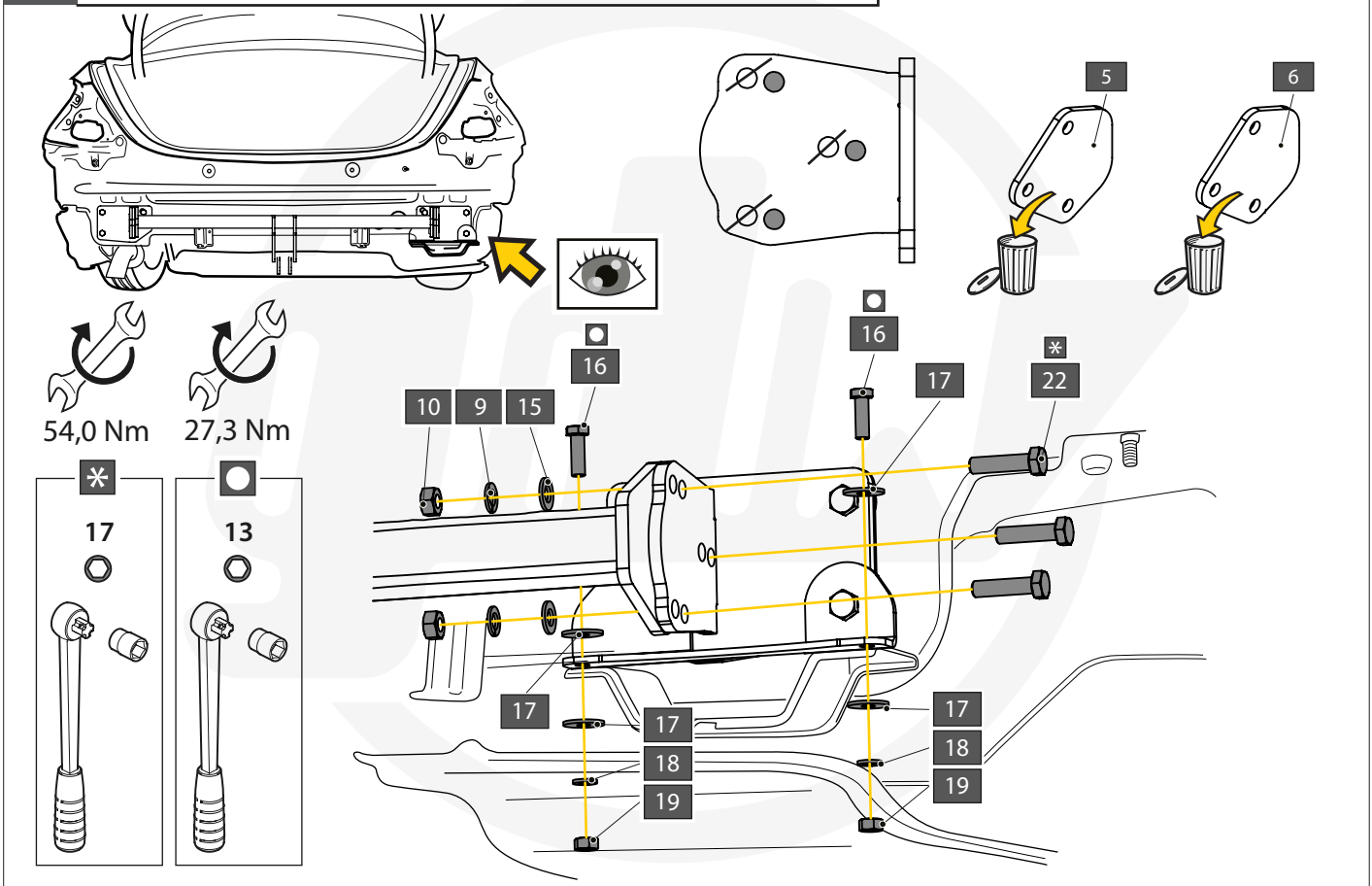

28 Only for W205/S205/A205/C205 Phase I/C238/A238

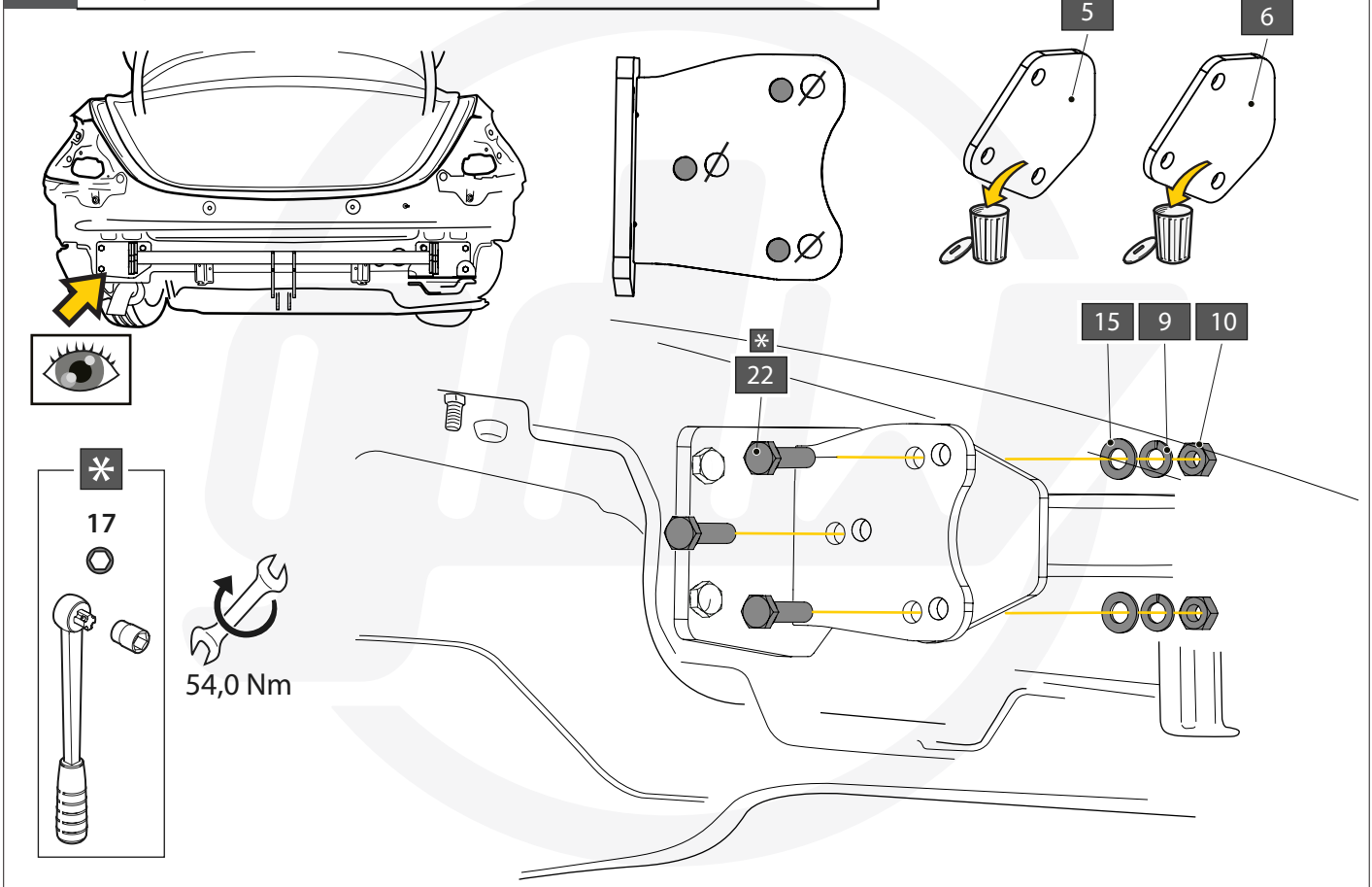

29 Only for C205 Phase II

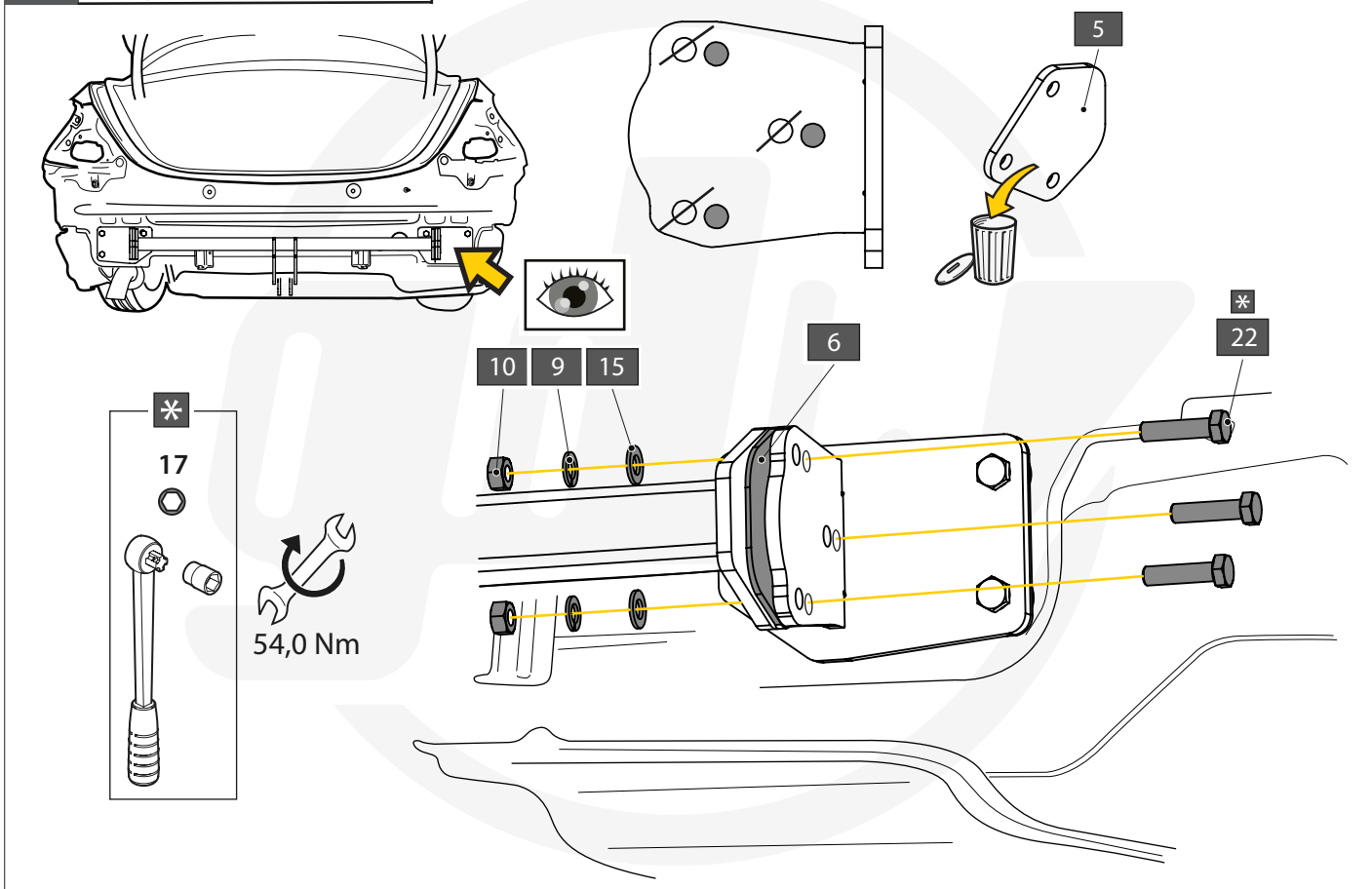

30 Only for C205 Phase II

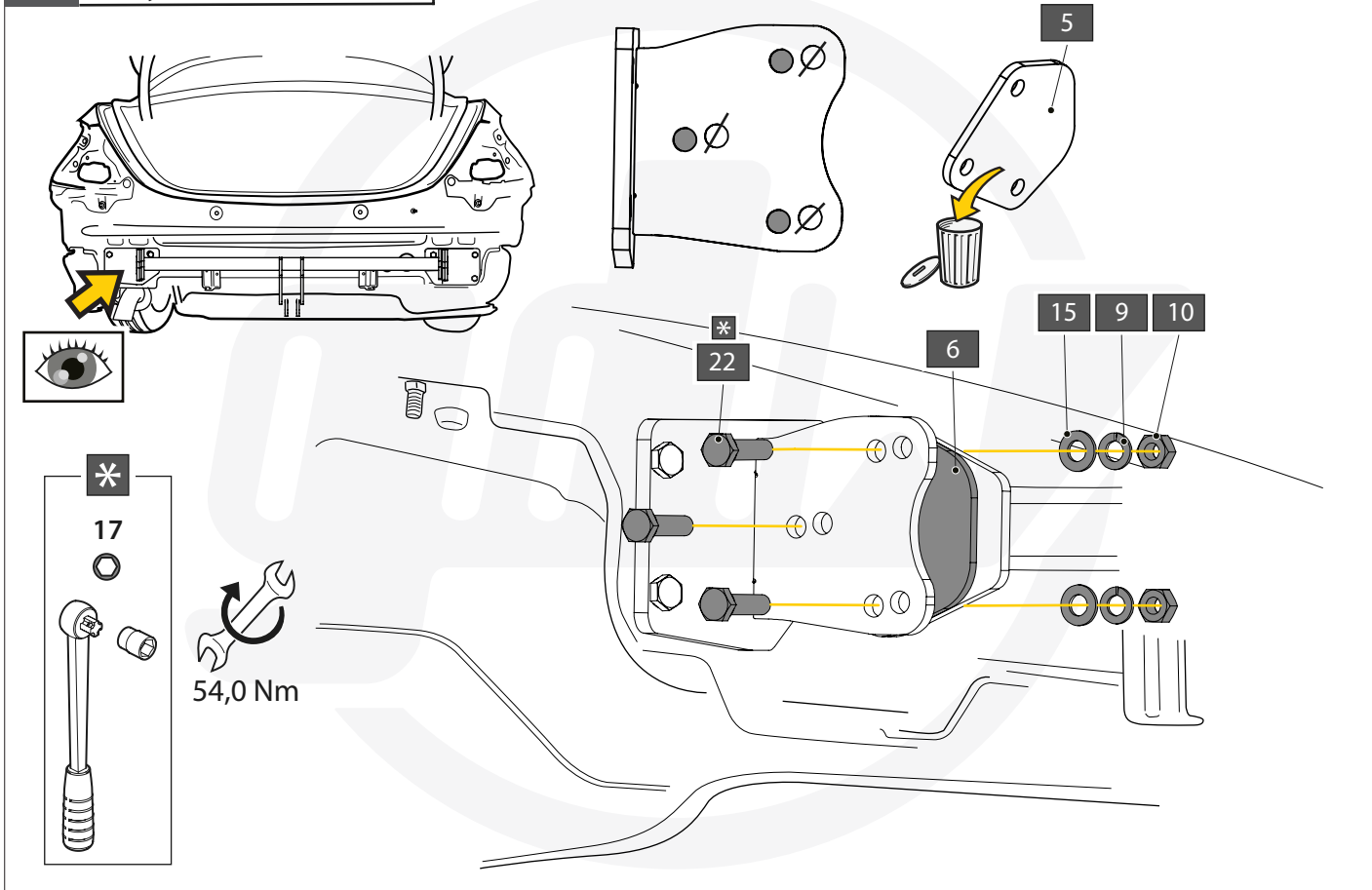

31 Only for S213

1 Standard & AMG-line

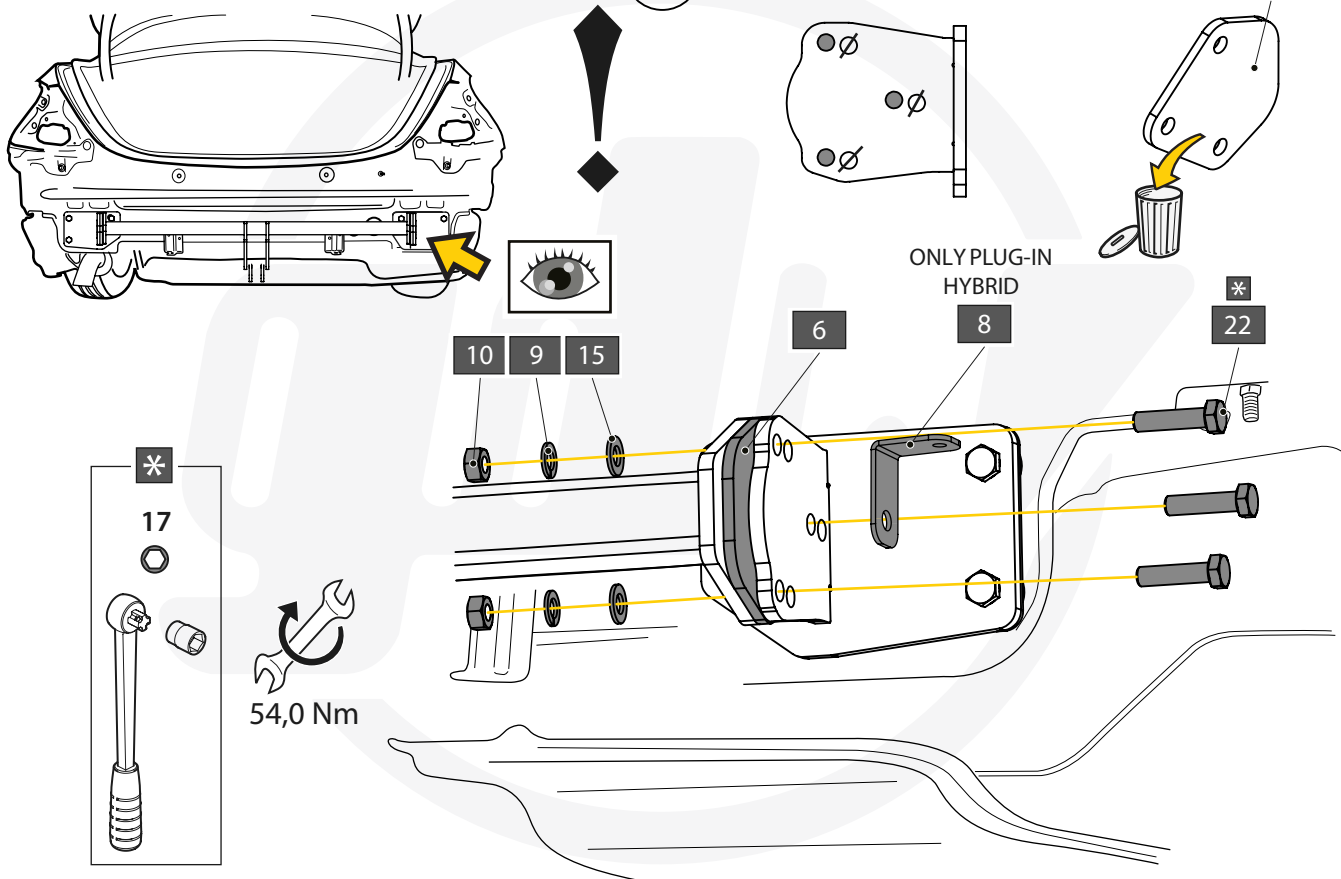

32 Only for S213

1 Standard & AMG-line

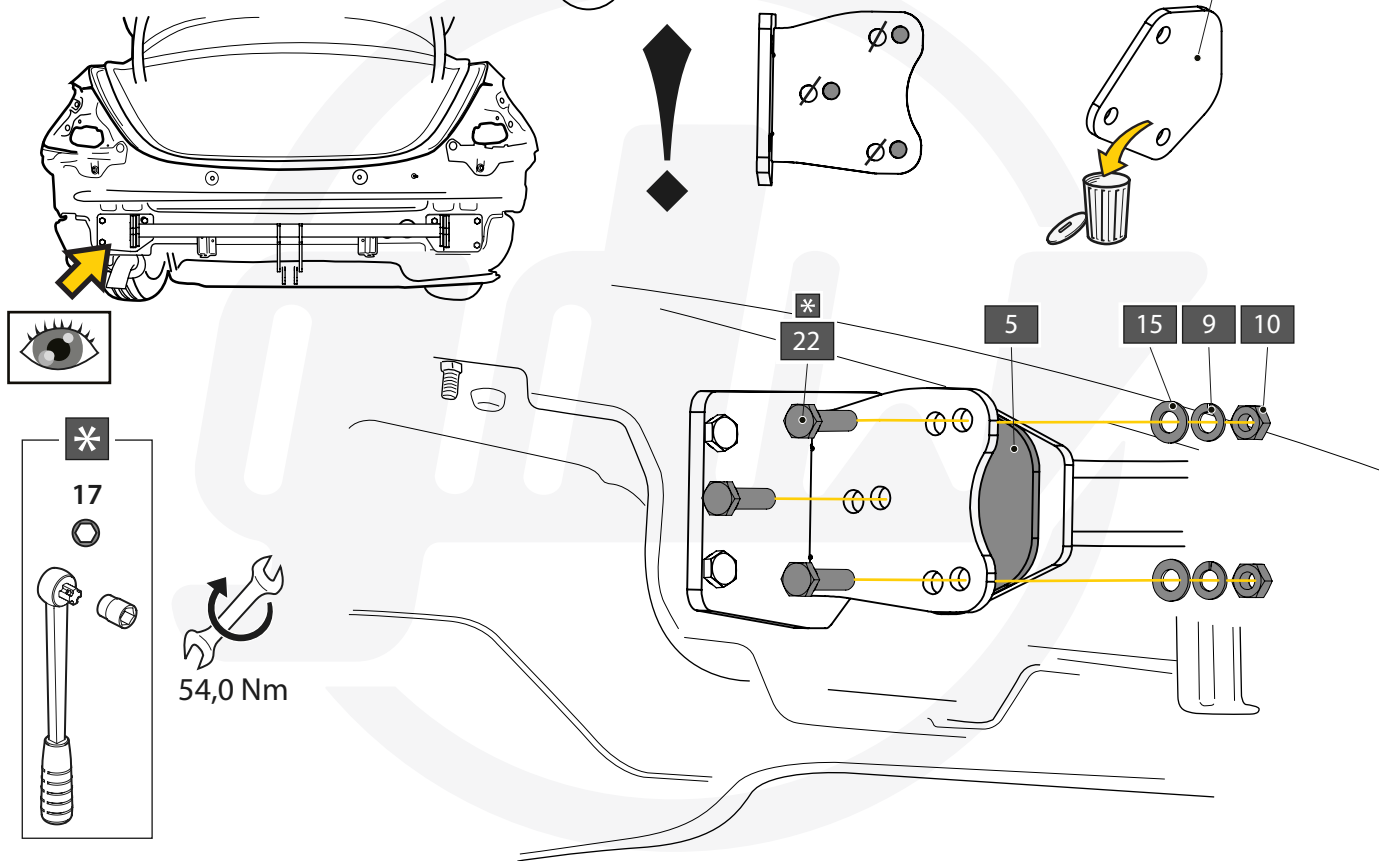

33 Only for W213

1 W213 STANDARD

2 W213 AMG-line

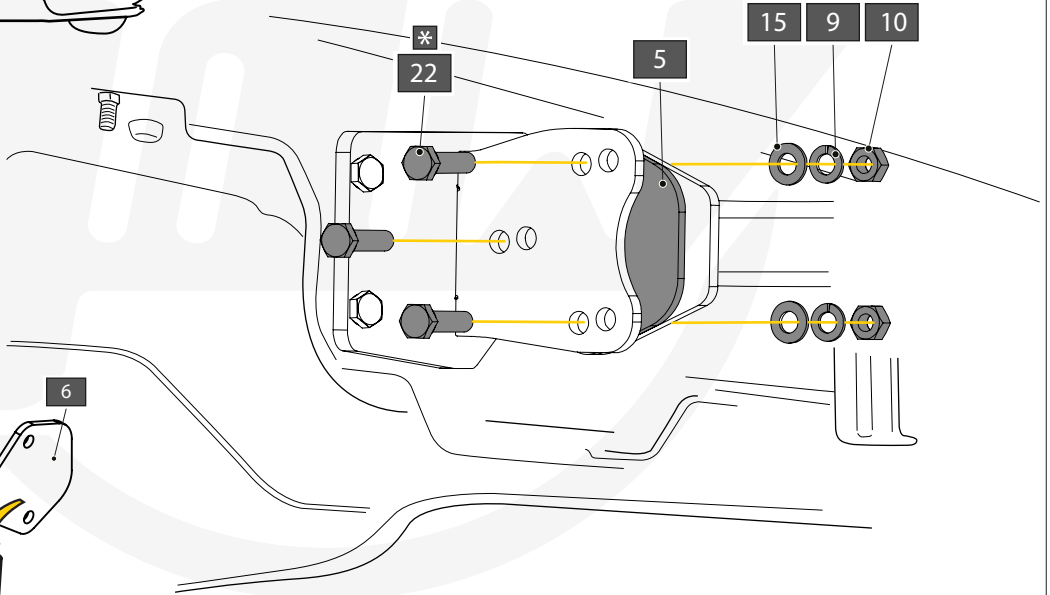
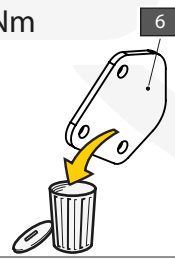
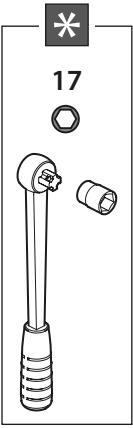
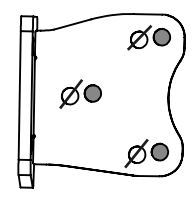
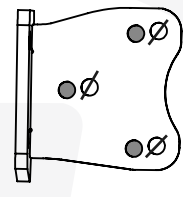
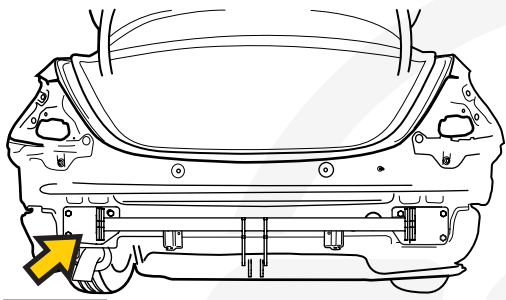

34 Only for W213

1 W213 STANDARD

2 W213 AMG-line

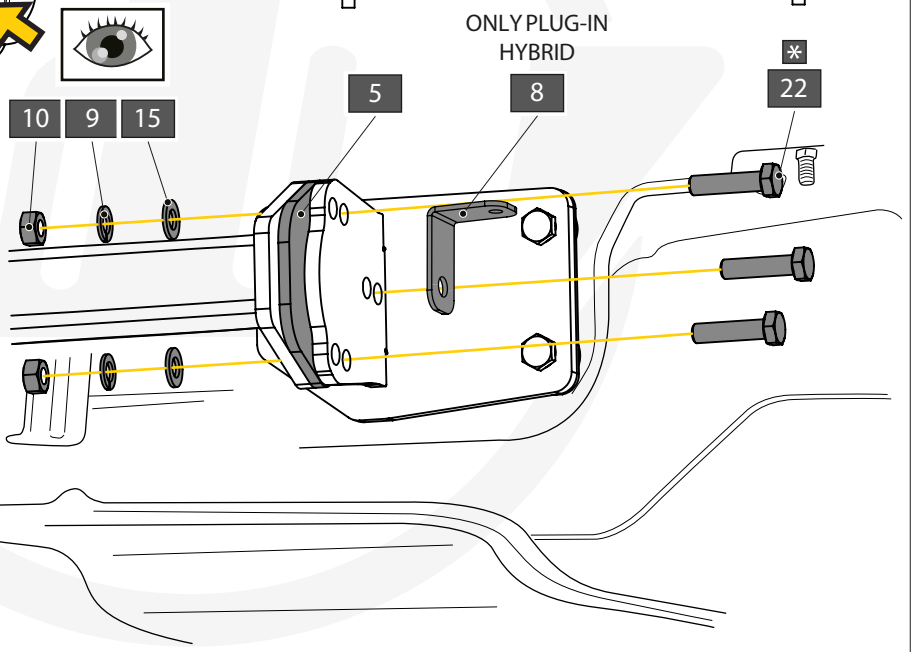
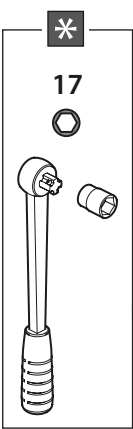
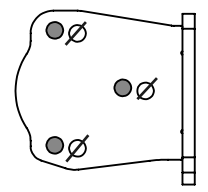
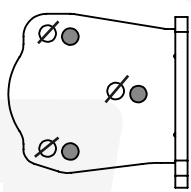
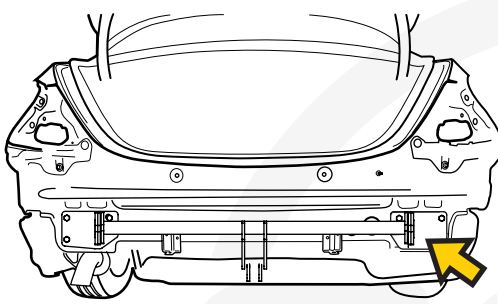

35 Only for W213 06/'20- + S213 07/'20-



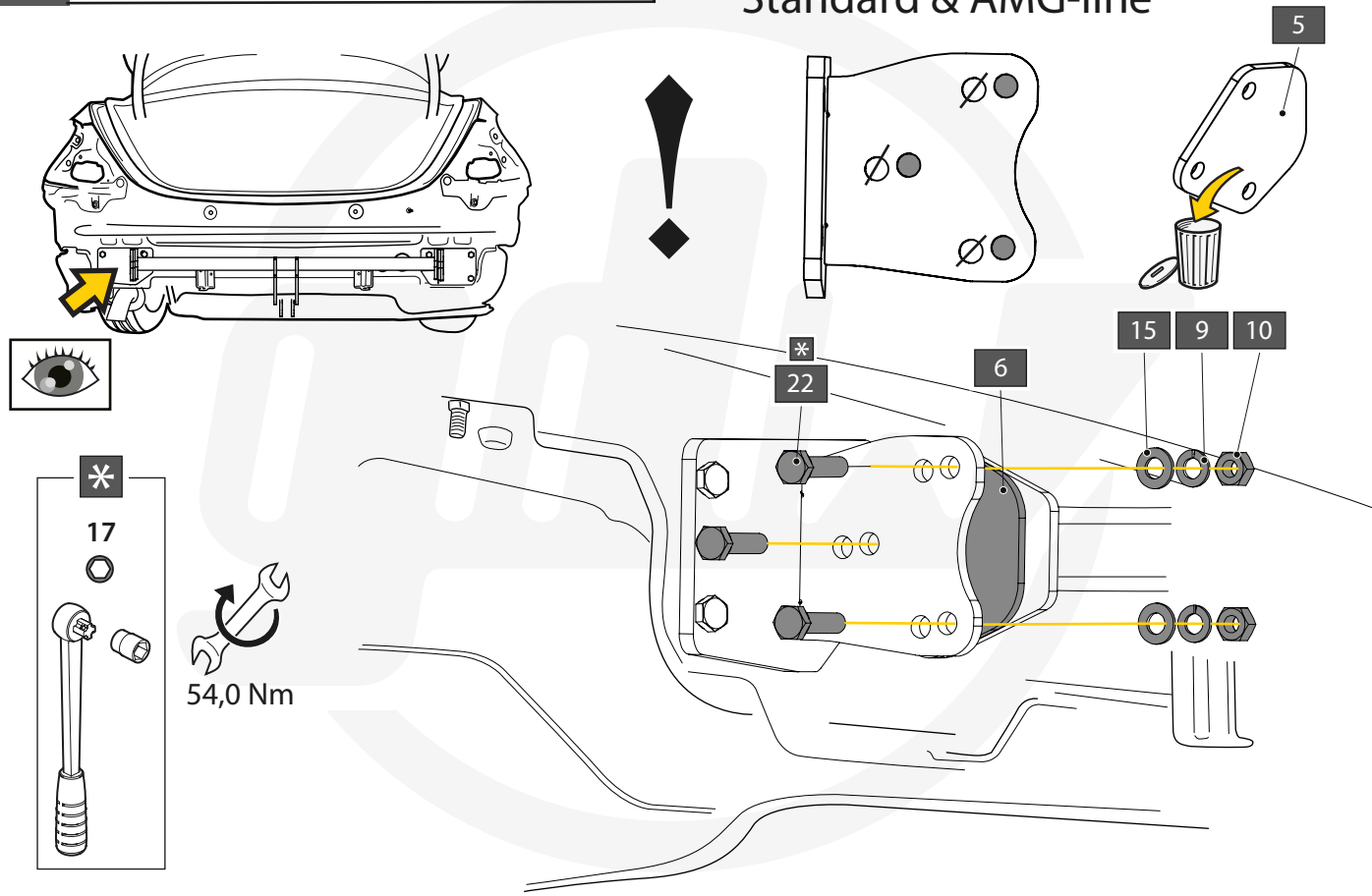



Standard & AMG-line

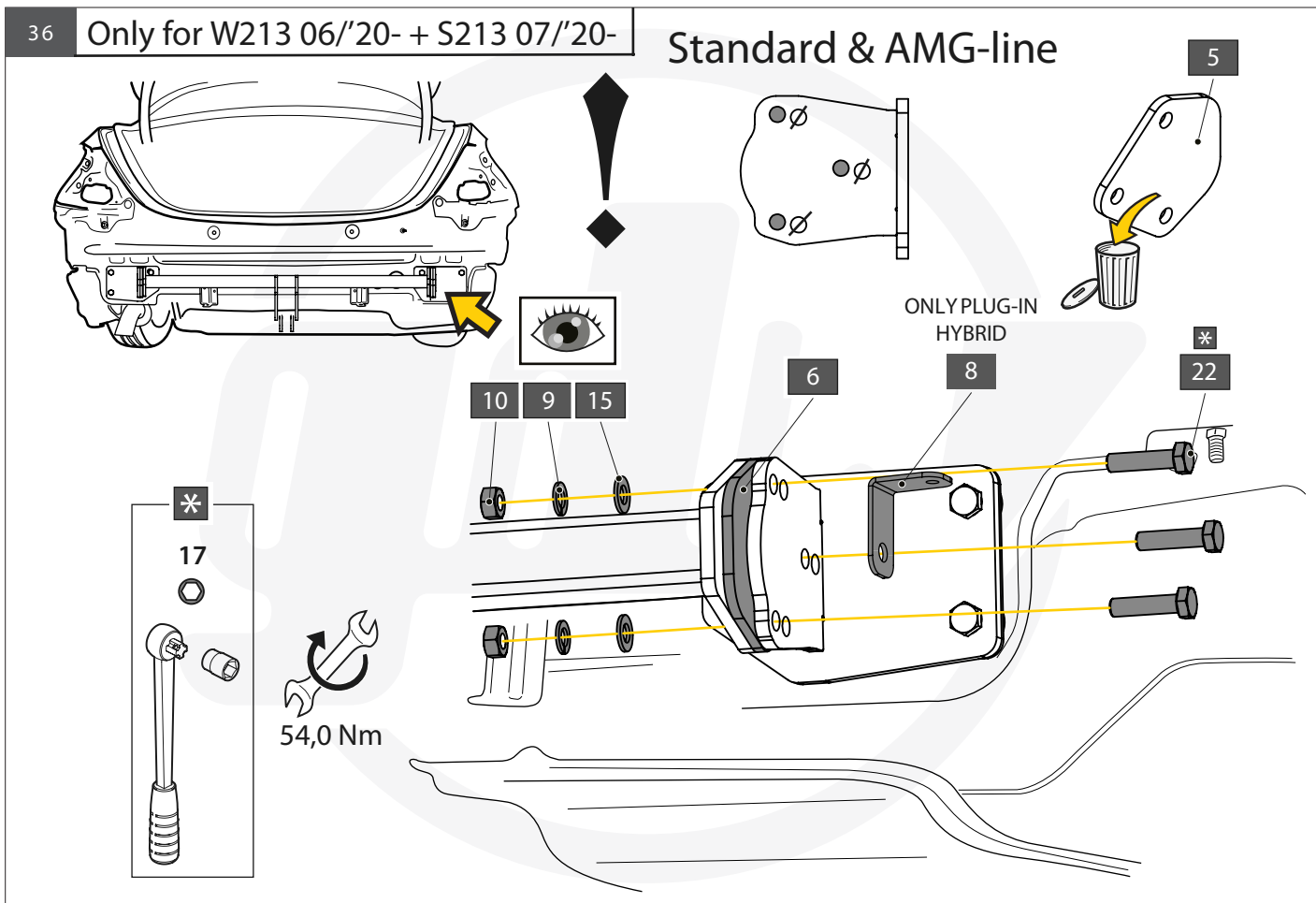

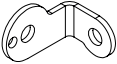

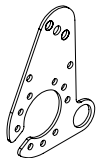

36 Only for W213 06/'20- + S213 07/'20-

Standard & AMG-line

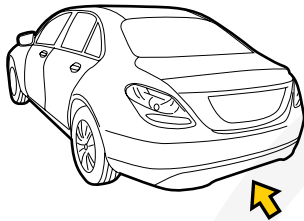
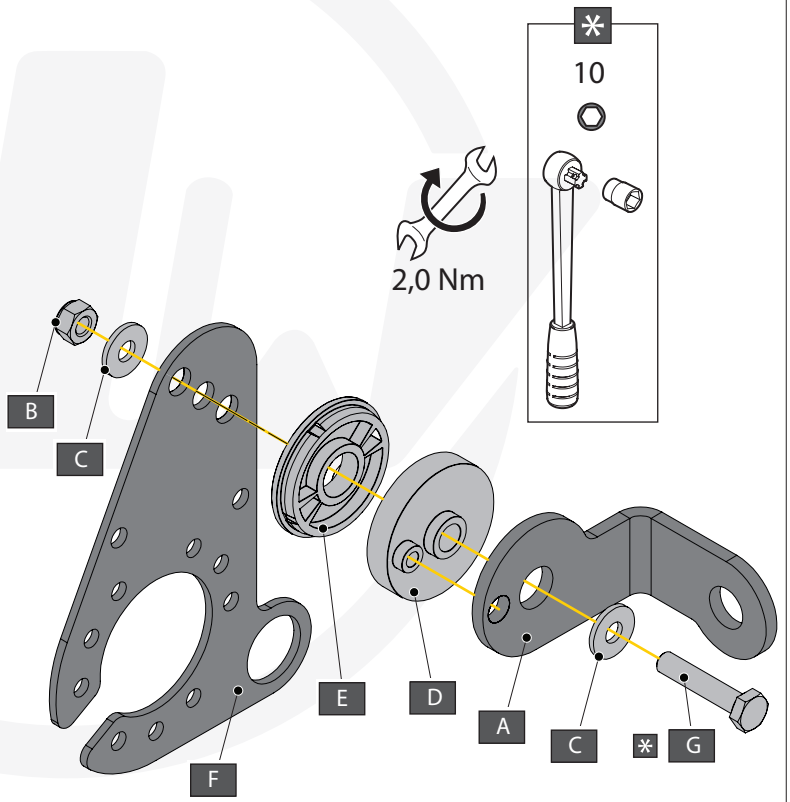

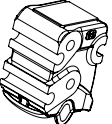



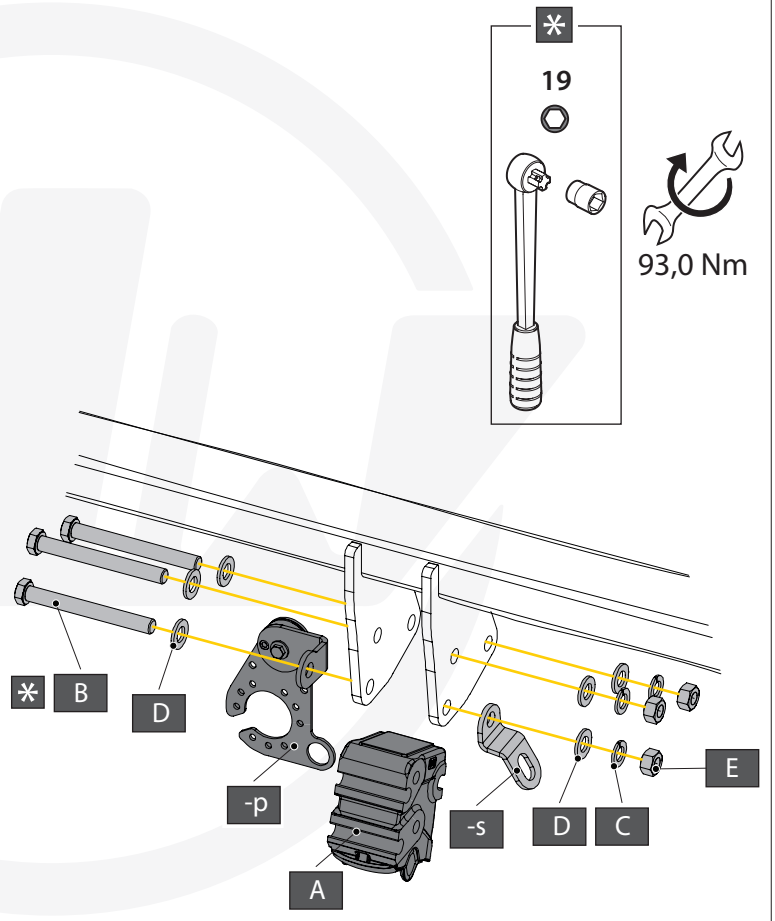

A		X1	GDW REF. 908.095
B		X1	DIN985-M6
C		X2	6,2 X 15,4 X 1,6 (NYLON)
D		X1	GDW REF. 718.16.002
E		X1	GDW REF. 718.16.003
F		X1	GDW REF. 908.094
G		X1	DIN933-M6 X 30

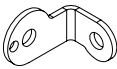

A		X1	912.003
B		X3	DIN931-M12X110
C		X6	DIN125A-M12
D		X3	DIN128A-M12
E		X3	DIN934-M12



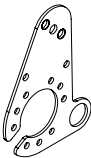

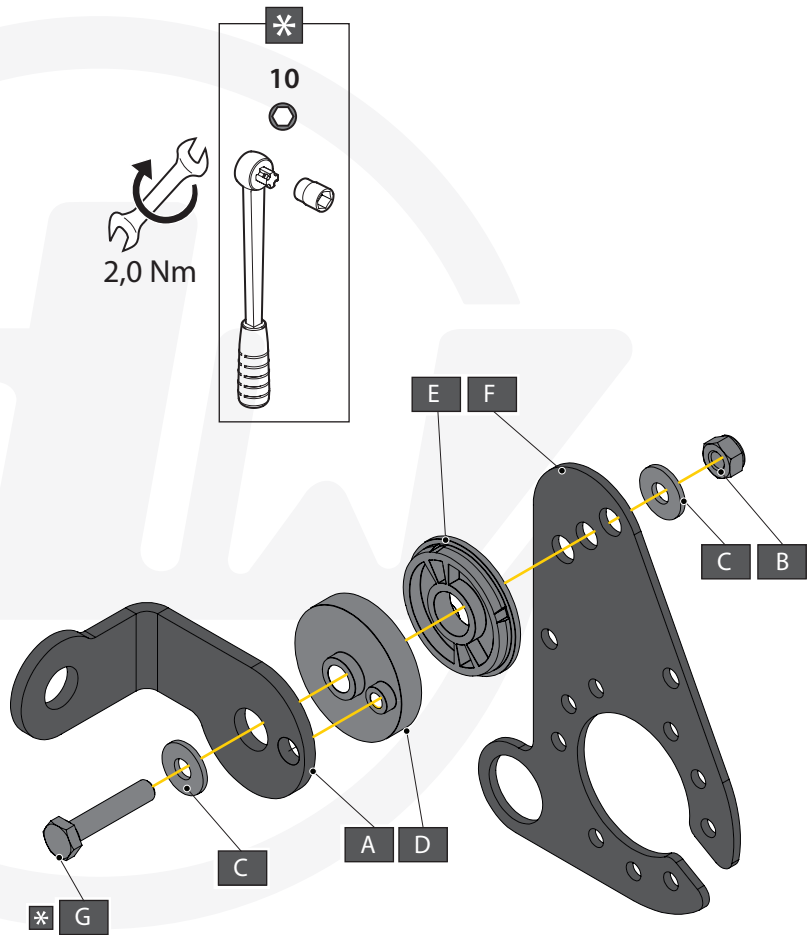

39 Only for S213 07/'20-

A		X1	GDW REF. 908.095
B		X1	DIN985-M6
C		X2	6,2 X 15,4 X 1,6 (NYLON)
D		X1	GDW REF. 718.16.002
E		X1	GDW REF. 718.16.003
F		X1	GDW REF. 908.094
G		X1	DIN933-M6 X 30

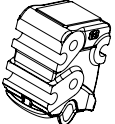

40 Only for S213 07/'20-

A		X1	912.003
B		X3	DIN931-M12X110
C		X6	DIN125A-M12
D		X3	DIN128A-M12
E		X3	DIN934-M12

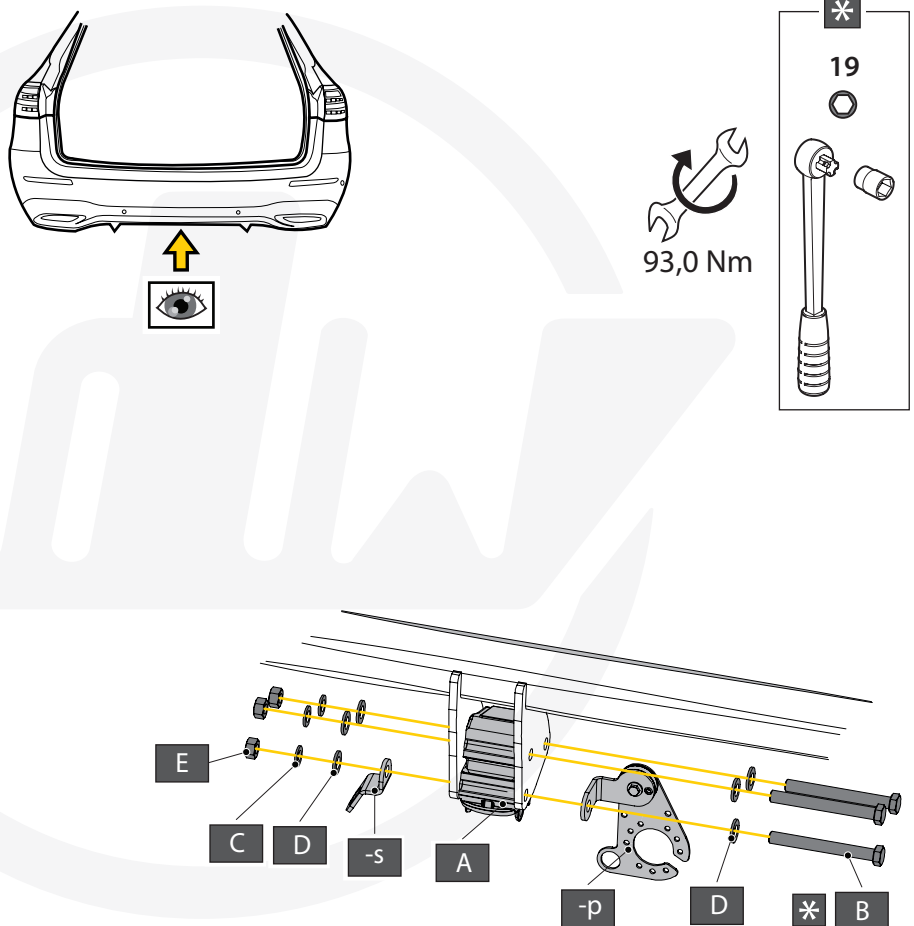

41 Only for W205, S205, A205 & C205 AMG-Line

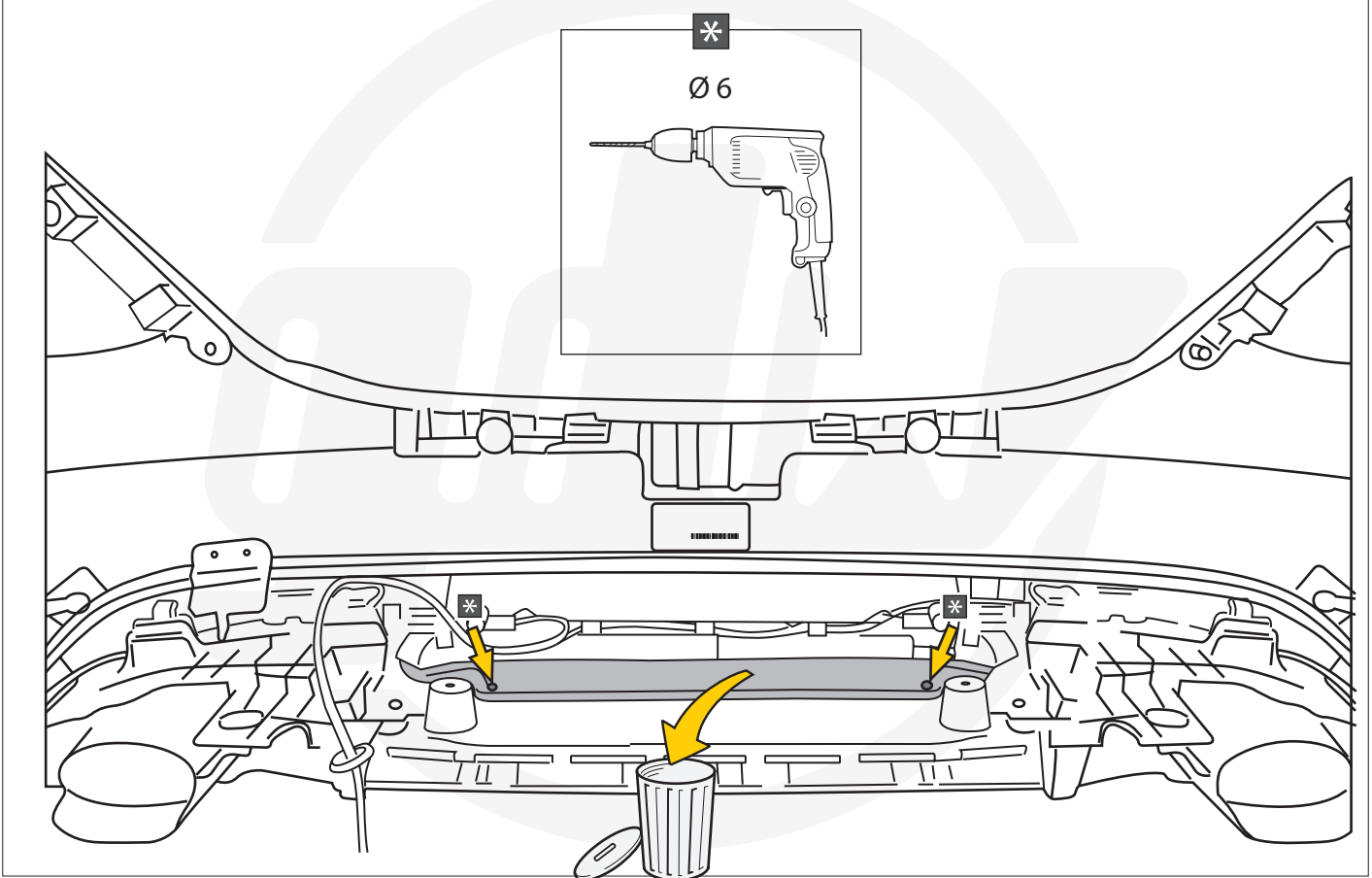

42 Only for W213 without AMG-line

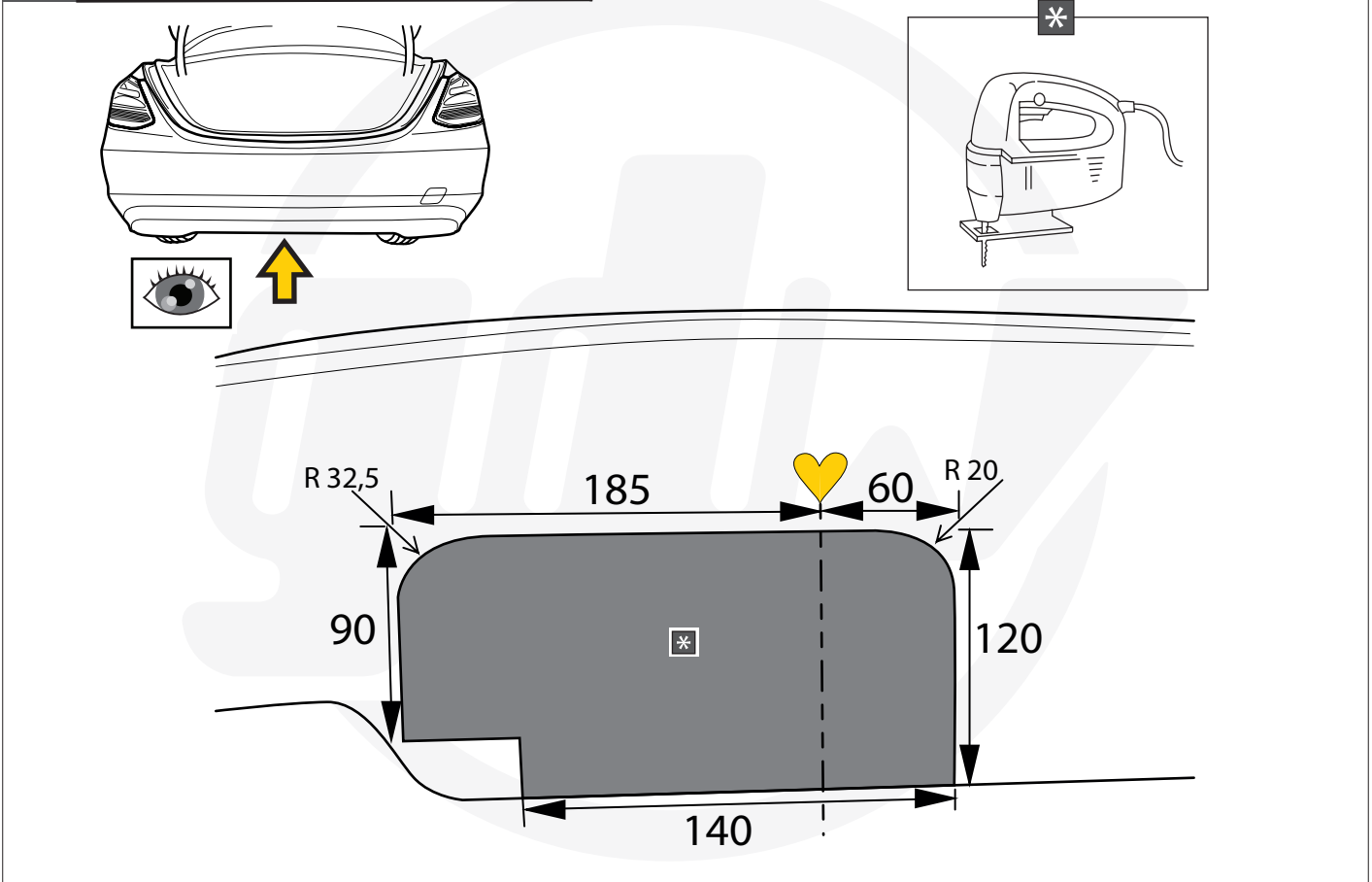

43 Only for W213 without AMG-line

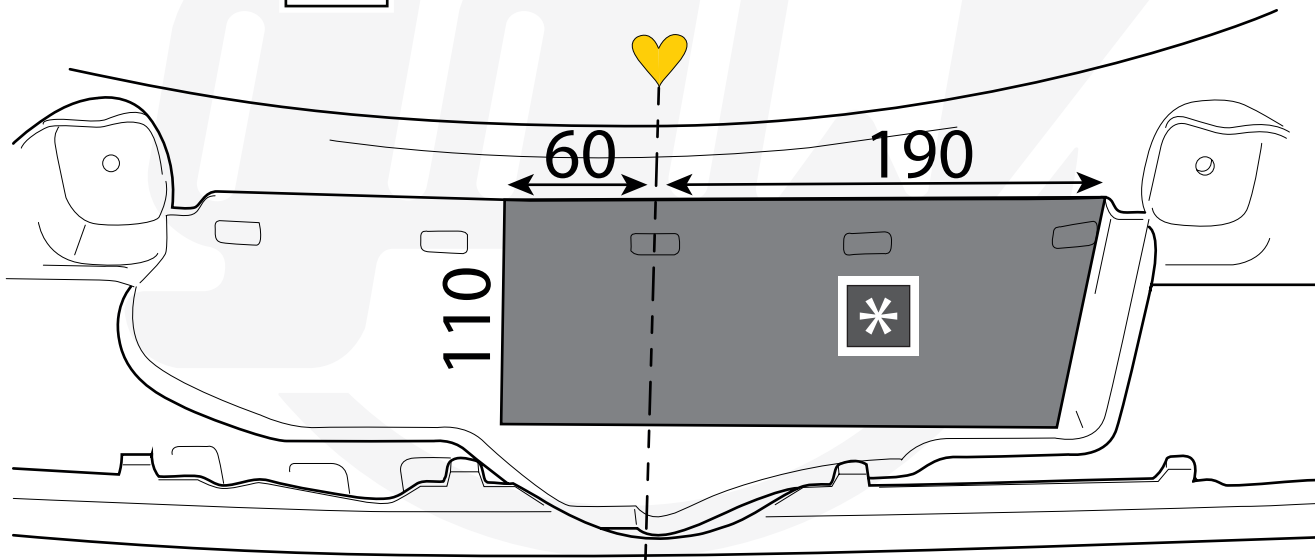
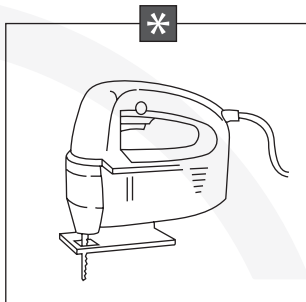
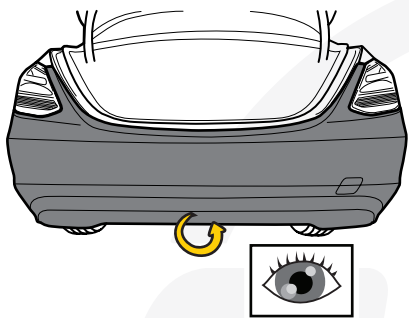

44 Only for W213 with AMG-line + S213 + S213 with AMG-line

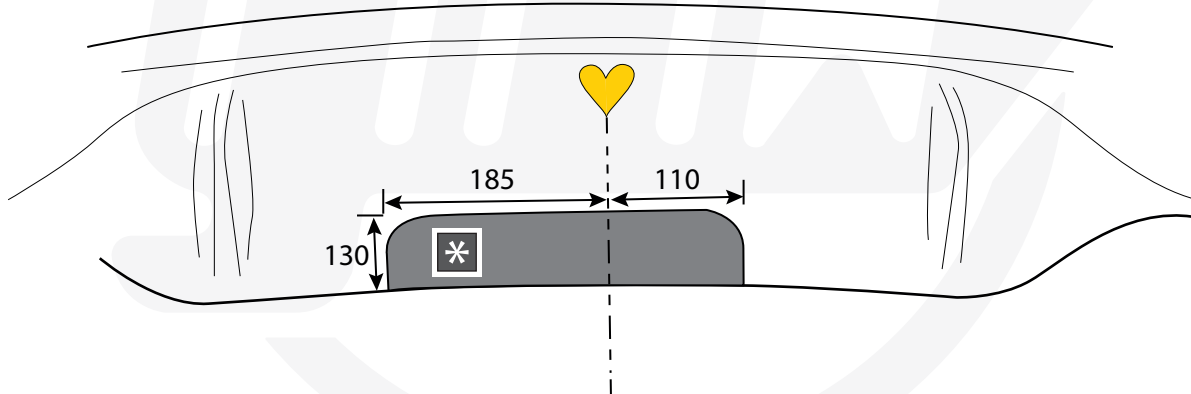
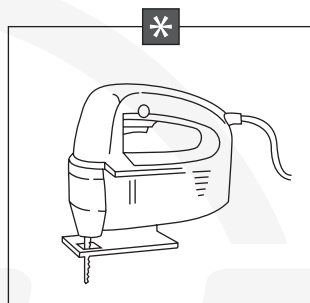
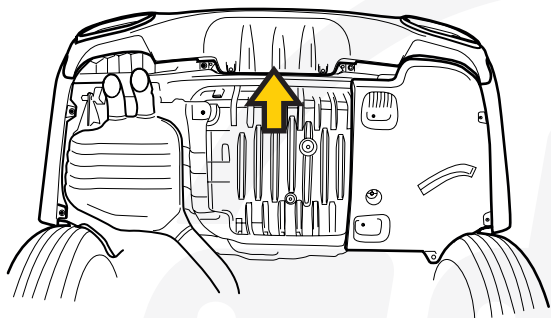

45 Only for W213 06/'20-

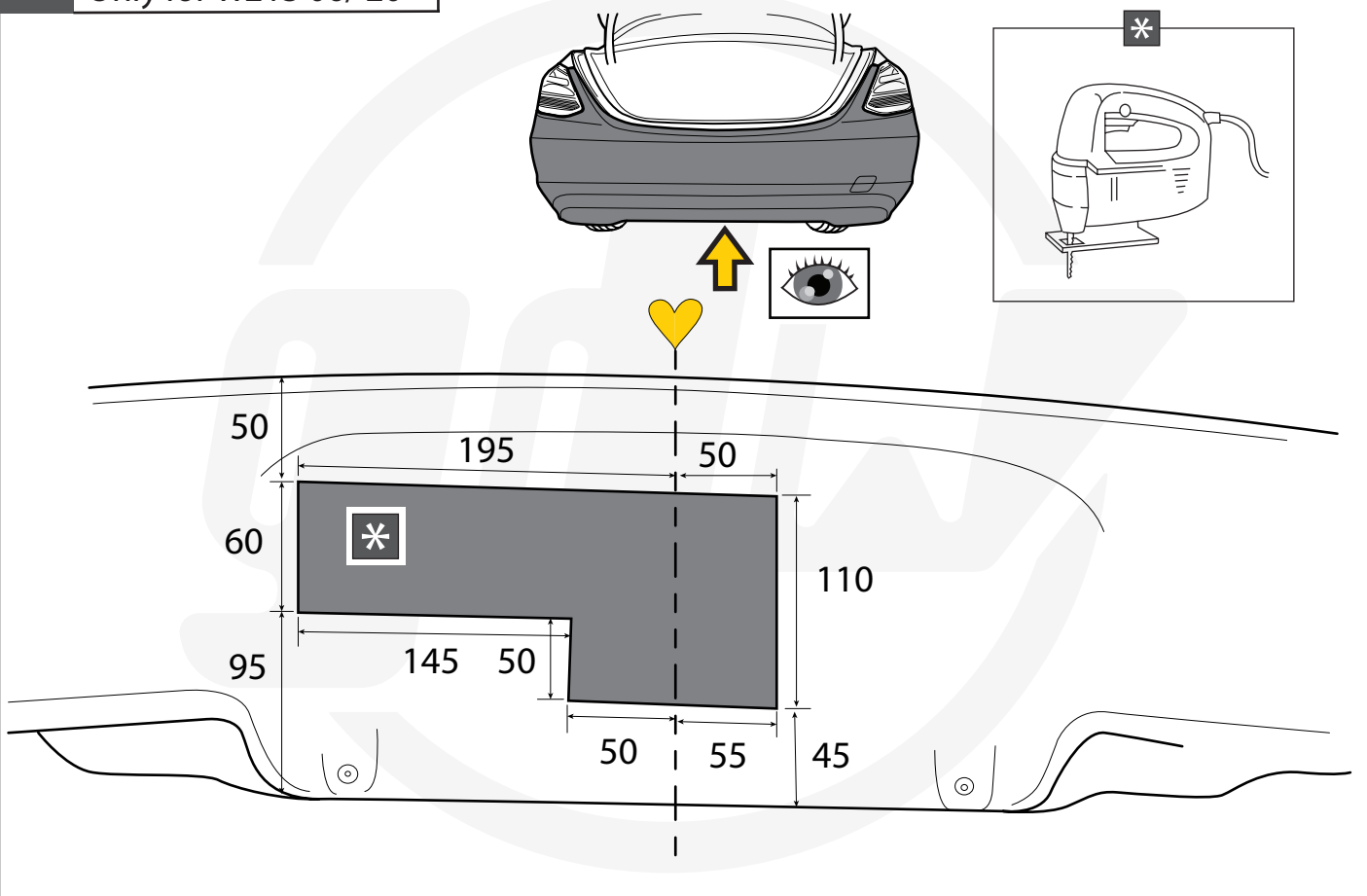

46 Only for S213 07/'20-

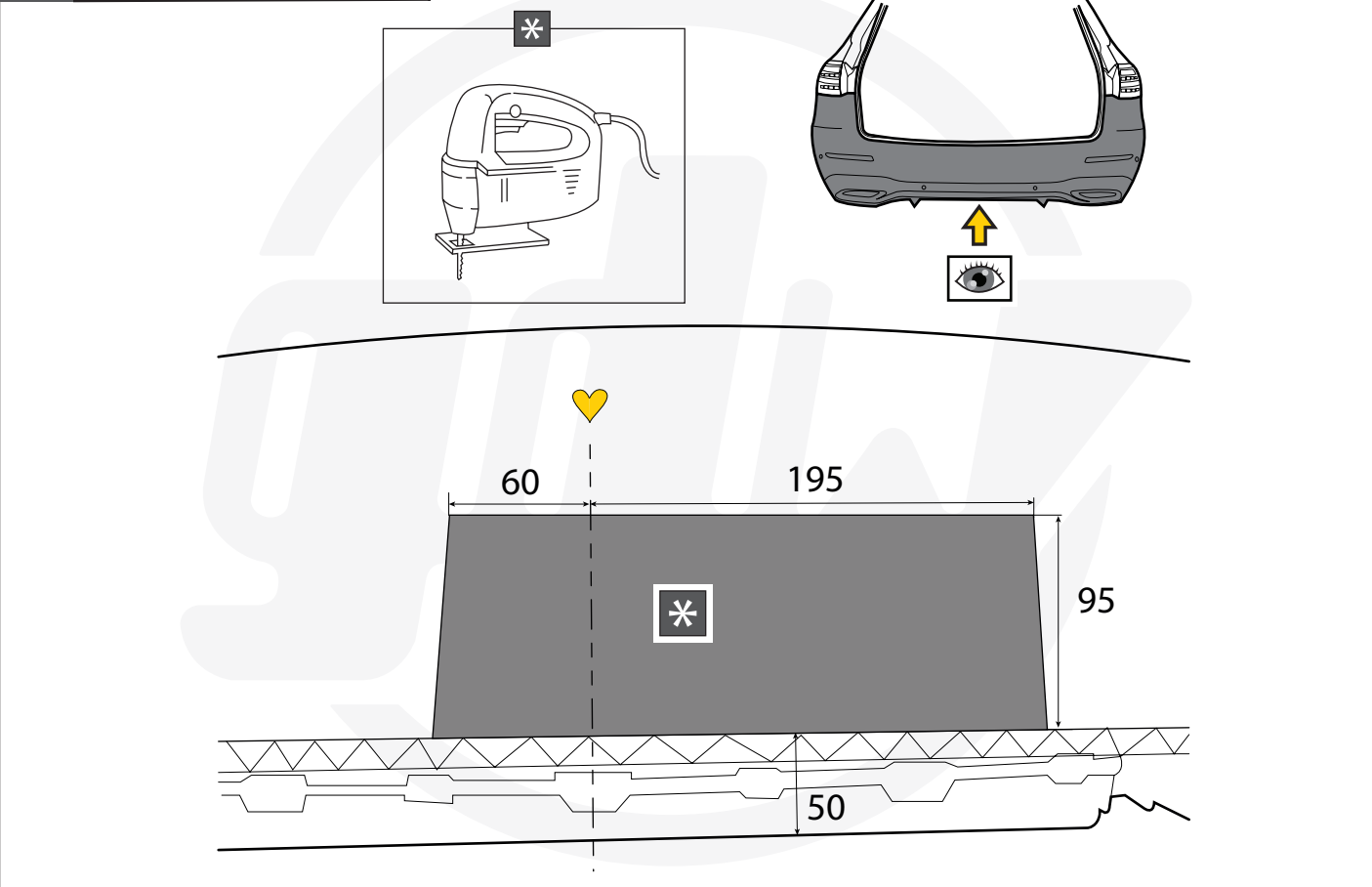

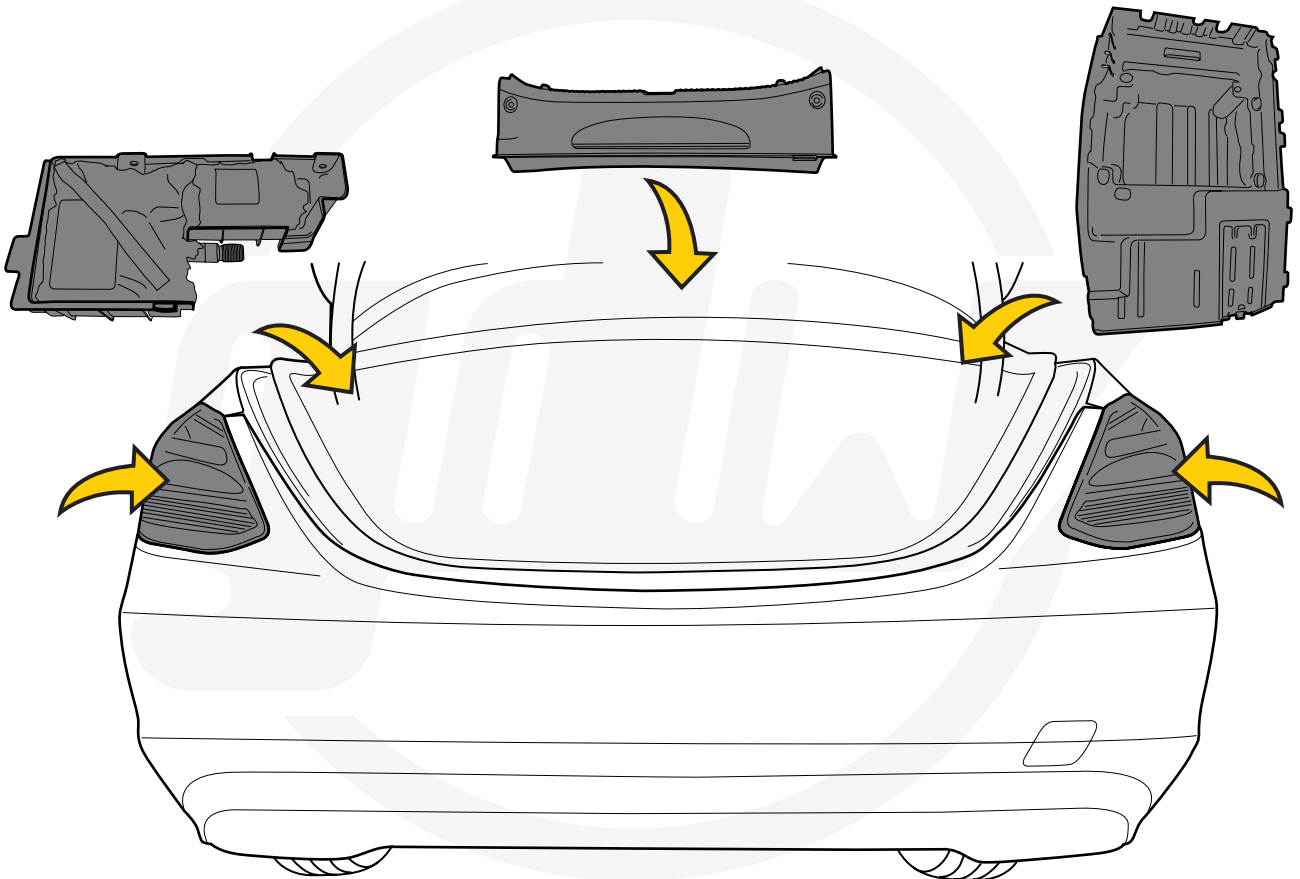
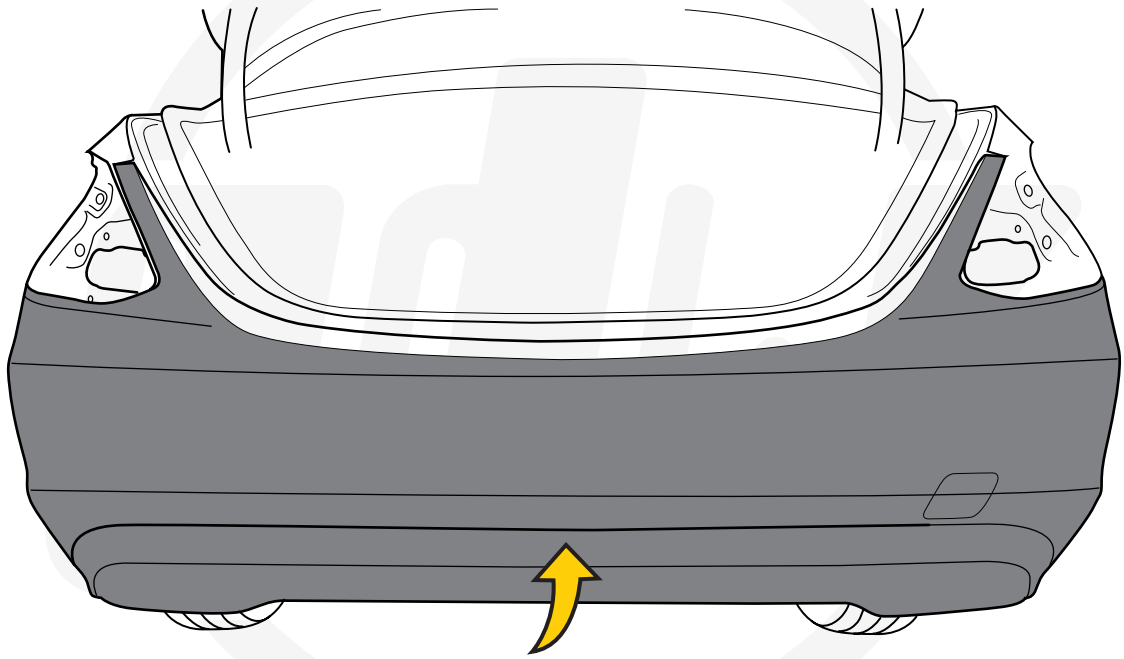

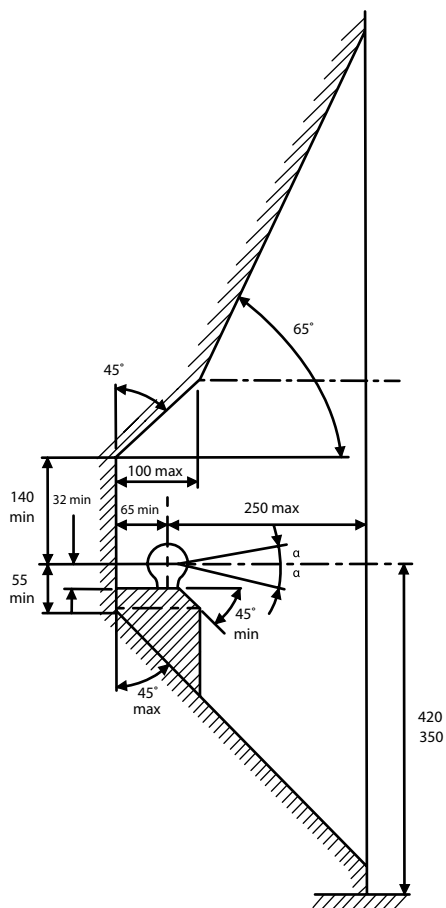

De tussenruimte conform bijlage VII, afbeelding 25 (a, b) van het reglement nr. 55 UN/ECE moet in acht genomen worden. Deze voorschriften zijn niet van toepassing op terreinvoertuigen klasse G.

La zone de dégagement doit être garantie conformément à l'annexe VII, illustration 25 (a, b) de la règle n° 55 UN/ECE. Ces dispositions ne s'appliquent pas aux véhicules tout-terrain classe G.

The clearance specified in appendix VII, diagram 25 (a, b) of regulation nr. 55 UN/ECE must be guaranteed. These requirements shall not apply to all-terrain vehicles class G.

Der Freiraum nach Anhang VII, Abbildung 25 (a, b) der Regulierung nr. 55 UN/ECE ist zu gewährleisten. Diese Vorschriften gelten nicht für Geländefahrzeugen Klasse G.

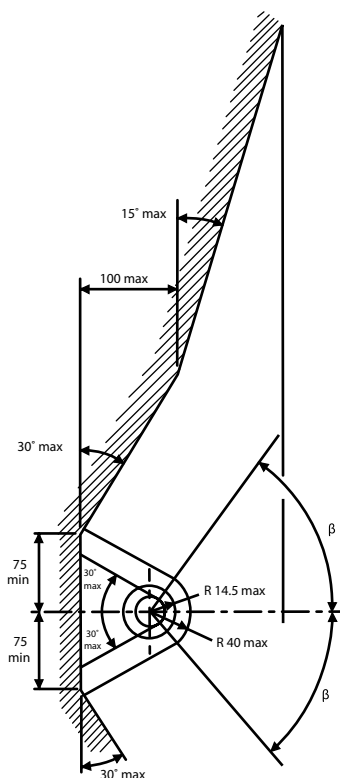

Bij toelaatbaar gewicht van het voertuig

Pour poids total en charge autorisé du véhicule

At laden weight of the vehicle

Bei zulässigem Gesamtgewicht des Fahrzeuges

Peso total admisible del vehículo

Ved tilladt samlet vægt for køretøjet

Peso totale ammissibile del veicolo